

Prepared by:

Wendell A. Smith
Wendell A. Smith, Esq.

BB 3770-110
3-22-89

MASTER DEED

THIS MASTER DEED, made this 21st day of March, 1989, by Clearbrook Partners, L.P., a New Jersey limited partnership having offices at 128 Sussex Way, Jamesburg, New Jersey (hereinafter referred to as the "Sponsor").

WHEREAS, the Sponsor is the owner of the fee simple title to those lands and premises described in Exhibit "A" attached hereto and made a part hereof, which lands and premises are hereinafter referred to as the "Condominium"; and

WHEREAS, the Sponsor is constructing 58 buildings, each containing from one to four residential dwellings ("Units"), for an aggregate of 136 Units; and

WHEREAS, it is the present intention of the Sponsor to establish the form of ownership of the aforescribed lands and premises as a condominium pursuant to the provisions of N.J.S.A. 46:8B-1 et seq. (the Condominium Act) under the name "Clearbrook Stuart Village, A Condominium, Section No. 18-A" and to that end to cause this Master Deed to be executed and recorded.

THEREFORE, WITNESSETH:

1. Establishment of Condominium

The Sponsor does hereby submit, declare and establish Clearbrook Stuart Village, A Condominium, Section No. 18-A in accordance with N.J.S. 46:8B-1 et seq. for that parcel of land described in Exhibit "A" aforesaid, all as shown on those certain maps entitled "Stuart Village, Survey and Easement Plan" and "Stuart Village, Building Location Plan" prepared by Lynch, Carmody, Guiliano and Karol, P.A., Consulting Engineers - Land Surveyors - Planners, Terrace Professional Building, 582 Plaza Terrace East, Brick Township, New Jersey, and attached hereto as Exhibit "B" and made a part hereof.

2. General Description

The Condominium will contain fifty-eight (58) buildings containing 136 Units as shown on Exhibit "B," and includes all rights, roads, water, privileges and appurtenances thereto belonging to or appertaining. Each Unit will be designated by a letter and by the number of the building of which each such Unit is a part.

BB 3770 p 110 Rec. 3/22/89

3. Description of Units

The dimensions, area and location of the Units are as shown graphically on Exhibit "B" aforesaid, and the architectural drawings attached hereto and made a part hereof as Exhibit "C," as same may be amended from time to time as herein provided. Each unit and any garage included within it, is intended to contain all space within the area bounded by the undecorated interior surfaces of the exterior walls, the first floor, and the ceiling as follows:

BOTTOM: The bottom of the unit is an imaginary horizontal plane through the lowest point of the interior surface of its lowest floor or subfloor, where applicable, and extending in every direction to the point where it closes with each side.

TOP: The top is an imaginary plane along and coincident with the unfinished and unexposed upper surface of the gypsum board or other material which forms its uppermost ceiling and extending in every direction to the point where it closes with each side.

SIDES: The sides of each unit are imaginary vertical planes along and coincident with the innermost surface of the studding of the perimeter walls and extending in every direction so as to close the area bounded by the bottom and top. Where no wall exists, the side is an imaginary plane running vertical and coincident with the exterior surface of the windows or doors located on the perimeter walls.

Each unit also includes all appliances, fixtures, windows, interior partitions and other improvements located within or appurtenant to it which are exclusive to such unit, although all or part thereof may not be located within the unit, and shall include but not be limited to the following individual appurtenances:

(a) Complete heating system and any air conditioning system (including compressors) which may be installed.

(b) So much of the plumbing system as extends from the walls or floors into the interior air space.

(c) All utility meters not owned by the public utility or agency supplying service.

(d) So much of the electrical wires as extend from the ceilings, walls or floors into the interior air space, and all fixtures, switches, outlets and circuit breakers.

4. Common Elements

A. General Common Elements: All appurtenances and facilities and other items which are not part of the Units as hereinbefore

described in Paragraph 3 shall comprise the Common Elements, as graphically shown on Exhibit "B." The Common Elements shall also include by way of description but not by way of limitation:

(i) All lands described in Exhibit "A" aforesaid, whether or not occupied by buildings containing Units.

(ii) All streets, curbs, sidewalks, parking areas subject to the easements and provisions set forth in Paragraph 6 hereof.

(iii) Lawn areas, shrubbery, conduits, utility lines and waterways, subject to the easements and provisions set forth in Paragraph 6 hereof.

(iv) The electrical and telephone wiring network throughout the Condominium not owned by the public utilities providing such services.

(v) Public connections for gas, electricity, light, telephone and water not owned by the public utility or other agencies providing such services.

(vi) The foundations, main walls (including doors and chimneys therein), roofs, and common areas of the Buildings.

(vii) Exterior lighting and other facilities necessary to the upkeep and safety of the buildings and grounds.

(viii) Any easement or other right hereafter granted for the benefit of the Unit Owner(s) for access to or use of recreational or other Common Elements not included within the lands which are part of the Condominium or for any other purpose.

(ix) All other elements of the Condominium rationally of common use or necessary to the existence, upkeep and safety thereof.

B. Limited Common Elements: The Limited Common Elements are those Common Elements which are restricted for the use of one or more specified Units to the exclusion of other Units, and shall be as graphically shown on Exhibits "B" and "C." The Limited Common Elements shall include:

(i) Any interior foyer, entranceway, stairway or hallway shared by more than one Unit shall constitute a Limited Common Element for the exclusive use of those Units having direct access thereto from their interiors.

(ii) Any balcony or patio, including any enclosed patio, appurtenant to any Unit shall be a Limited Common Element for the exclusive use of those Units to which such balcony or patio are appurtenant.

The owners of the Units entitled to the use of any Limited Common Element shall be responsible for all repairs thereto necessitated by their own negligence, misuse or neglect. Any other repairs or maintenance of the Limited Common Elements shall be the responsibility of the Condominium Association, together with expense of lighting the Limited Common Elements.

5. Estate Acquired; Interest in Common Expenses and Common Surplus; Voting

The owners of each Unit shall have such an estate therein as may be acquired by grant, by purchase or by operation of law, including an estate in fee simple, and shall acquire as an appurtenance to such Unit, an undivided interest in the Common Elements of the Condominium as set forth in Exhibit "F" attached and made a part hereof, and shall remain fixed subject to any amendments as herein provided. The undivided interest in the Common Elements shall not be divisible from the Unit to which it appertains. Said percentage is expressed as a finite number to avoid an interminable series of digits; the fourth decimal has been adjusted to that value which is most nearly correct. Said percentage shall be used to allocate the division of proceeds, if any, resulting from any casualty loss, any eminent domain proceeding, any common surplus or from any other disposition of the Condominium property. Anything to the contrary notwithstanding, voting rights of each unit and its proportional liability for common expenses shall not be based upon the foregoing percentage but instead, upon that fraction the numerator of which is one (1) and the denominator of which is one hundred thirty-six (136). Each unit in the Condominium shall pay the same amount for common expenses which amount shall equal that fraction of the total common expenses for the Condominium whose numerator is one and whose denominator is one hundred thirty-six (136).

6. Easements

(a) Sponsor, for itself, its successors and assigns, hereby declares that every Unit Owner shall have a perpetual non-exclusive easement in, upon, through and over the land described in Exhibit "A" aforesaid, to keep, maintain, use, operate, repair and replace his Unit in its original position and in every subsequent position to which it changes by reason of the gradual forces of nature and the elements.

(b) The Sponsor hereby reserves unto itself, its successors and assigns an easement in, upon, through and over the Common Elements for as long as the Sponsor, its successors and assigns, shall be engaged in the construction, development, and sales of Units, which easement shall be for the purpose of construction, installation, maintenance and repair of existing buildings and appurtenances thereto, for ingress and egress to all Units, all Common Elements and other community facilities and for the use of all roadways, parking lots, and existing and future model Units for sales promotion and exhibition. In addition, the Sponsor hereby reserves the irrevocable

right to enter into, upon, over or under any Unit for a period of one (1) year after the date of delivery of the Unit Deed for such purposes as may be reasonably necessary for the Sponsor or its agents to complete the Condominium or service any Unit thereof. Such request for entry shall be made in advance and any such entry is at a time reasonably convenient to the Unit Owner. In the case of an emergency, such right of entry shall be immediate whether the Unit Owner is present or not and without a prior request for entry to the Unit Owner.

(c) The Sponsor, for itself, its successors and assigns, hereby declares that every Unit owner and Member of Clearbrook Community Association shall have a perpetual and non-exclusive easement in, upon, over, across and through the Common Elements for ingress and egress to his Unit and the Common Elements of the Condominium in which it is located and the common facilities of the Clearbrook Community Association.

(d) The Sponsor, for itself, its successors and assigns, hereby declares that every Unit Owner shall have a perpetual, exclusive easement for possession and use of (i) those Common Elements such as porches, patios, stoops, and doorsteps appurtenant to his Unit which serve his Unit exclusively, and (ii) where applicable that portion of the lawn and paved area contiguous to the front and rear of the Unit indicated by dotted lines on Exhibit "B," if any ("Exclusive Lawn Easement").

(e) The Sponsor, for itself, its successors and assigns, further declares that every Unit Owner shall have a perpetual and exclusive easement to use and enjoy the surfaces of the main walls, (including doors and chimneys therein), ceilings and floors contained within his Unit.

(f) The Sponsor reserves unto itself, its successors, assigns and agents, an easement in, upon, through and over the lands comprising the Common Elements for the purpose of installation, maintenance, repair and replacement of all sewer, water, power and telephone, pipes, lines, mains, conduits, waters, poles, transformers and any and all other equipment or machinery necessary or incidental to the proper functioning of any utility systems serving the Condominium.

(g) The Sponsor, for itself, its successors and assigns, hereby declares that every Unit Owner shall have a perpetual easement for the continuance of any encroachment by his Unit on any adjoining Unit or on any Common Element, now existing as a result of construction or which may come into existence hereafter as a result of reconstruction of the buildings or a unit after damage by fire or other casualty, or as a result of condemnation or eminent domain proceedings, so that any such encroachment may remain undisturbed so long as the buildings stand.

(h) The Sponsor, for itself, its successors and assigns, hereby declares that the Township of Monroe, Middlesex County, New Jersey (but not the public in general) shall have a perpetual non-exclusive easement to enter upon all roadways, streams, lakes, parking areas, driveways, walkways and sidewalks, for purposes of maintaining the safety, health, welfare, police and fire protection of the citizens of said Township, including the residents of the Condominium.

(i) The Sponsor further declares that the Community Association and its members shall have a perpetual non-exclusive easement on, over and across Clearbrook Drive and such other streets and roadways within the Condominium as may be necessary or appropriate for ingress and egress to the Community and travel through the Community, which easement area shall be maintained, repaired and replaced if necessary, by the Community Association as a community facility. The Board of Directors of the Condominium is empowered to grant, without payment or receipt of any consideration, a specific easement in recordable form confirming this easement.

(j) The Sponsor further declares that the Common Elements shall also be subject to a blanket, perpetual and non-exclusive easement in, upon, over, across and through the Common Elements for the purpose of installation, maintenance, repair, service, use and replacement of all sewer, water, power and telephone lines, pipes, mains, conduits, poles, transformers, meters, master television antennae and any and all other equipment or machinery necessary or incidental to the proper functioning of any irrigation or utility system serving the Community or any Unit in the Community, which easement shall be for the benefit of any governmental agency, or utility company or other entity which requires same for the purpose of furnishing one or more of the foregoing services.

7. By-Laws and Administration

The administration of the Common Elements of the Condominium and the Community and recreational facilities shall be by the Clearbrook Stuart Village Condominium Association No. 18-A, Inc. (hereinafter the "Condominium Association") and the Clearbrook Community Association in accordance with the provisions of the Condominium Act, this Master Deed, the Certificate of Incorporation and the By-Laws of the Condominium and Community Associations attached hereto as Exhibits "D," "E," "G" and "H", respectively, and made a part hereof, and any other documents, amendments or supplements to the foregoing which may subsequently be required by an institutional mortgage lender, or by any governmental agency having regulatory jurisdiction over the Condominium or by any title insurance company selected by the Sponsor to insure title to any Unit(s). In order to effectuate the above, if required as aforesaid, Sponsor hereby reserves for itself, its successors and assigns, for a period of the lesser of two (2) years from the date hereof, or until the last Unit in the

Condominium has been sold by Sponsor in the ordinary course of business, the right to execute on behalf of all contract purchasers, Unit owners, mortgagees, other lien holders or parties claiming a legal or equitable interest in the Condominium, any such agreements, documents, amendments or supplements which may be so required.

By acceptance of a deed to any Unit or by the acceptance of any other legal or equitable interest in the Condominium, each and every contract purchaser, Unit owner or occupant, or holder of any mortgage or other liens, does automatically and irrevocably name, constitute, appoint and confirm the Sponsor, its successors and assigns, as attorney-in-fact for the purpose of executing such amended Master Deed(s), or other instrument(s) necessary to effect the foregoing. The power of attorney aforesaid is expressly declared and acknowledged to be coupled with an interest in the subject matter hereof and the same shall run with the title to any and all Condominium units and be binding upon the successors and assigns of any of the foregoing parties. Further, said power of attorney shall not be affected by the death or disability of any principal and is intended to deliver all right, title and interest of the principal in and to said power. Except as herein provided this Master Deed may not be modified or amended without the acquiescence of all Unit Owners. All amendments or modifications shall be evidenced by an Amendment to the Master Deed which Amendment shall be recorded in the Middlesex County Clerk's Office.

8. Restrictions

The Condominium is subject to all covenants, restrictions and easements of record. It is further subject to the zoning ordinance of Monroe Township which restricts permanent occupancy to persons who are 48 years of age or over. The Condominium is also subject to the following restrictions:

(a) Nothing shall be done or kept in any Unit or in or upon the Common Elements which will increase the rates of insurance of the Condominium or any other Unit, or either of their contents, beyond the rates normally applicable, without the prior written consent of the Condominium Association. No Unit Owner shall permit anything to be done or kept in his Unit or in or upon the Common Elements which will result in the cancellation of insurance on the Condominium, or which will be in violation of any law.

(b) No noxious or offensive activities shall be carried on, in or upon the Common Elements or in any Unit nor shall anything be done therein either willfully or negligently which may be or become an annoyance or nuisance to the other residents of the Condominium.

9. Obligations of Sponsor

The Sponsor covenants and agrees that for so long as it owns one or more of the Condominium Units, the Sponsor shall be subject to the

provisions of this Master Deed and of all exhibits attached hereto; and the Sponsor covenants to take no action that will adversely affect the rights of the other owners of units and their successors in interest, as their interests may appear.

10. No Partition

Subject to the provisions of the Master Deed, By-Laws of the Association, and the Condominium Act, the Common Elements shall remain undivided and no Unit Owner(s) shall bring any action of partition or division thereof. In addition, the undivided percentage interest in the Common Elements shall not be separated from the Unit to which it appertains and shall be deemed conveyed or encumbered with the Unit even though such interest is not expressly mentioned or described in the conveyance or other instrument.

11. Compliance by Owners

Each unit owner or occupant shall comply with the provisions of this Master Deed, the By-Laws and the rules and regulations of both the Condominium Association and the Clearbrook Community Association or their representatives, and with any other documents, amendments or supplements to the foregoing now or hereafter lawfully adopted. Failure to comply with any such provision, rules or regulations shall be grounds for injunctive relief by the Grantor, the Condominium Association, Clearbrook Community Association and any other Unit Owner.

12. Restrictions Against Short Term Leases

No Unit shall be rented by the owners thereof (for transient or hotel purposes, which shall be defined as "(a) rental for any period less than thirty (30) days; or (b) any rental if the occupants of the Unit are provided customary hotel service, such as room service for food and beverage, maid service, furnishing laundry and linen, and bellboy service." Other than the foregoing obligations, the Unit Owners shall have the absolute right to lease same provided the said lease is made subject to the covenants and restrictions contained in this Master Deed, the By-Laws of both the Condominium Association and the Community Association, and other documents referred to herein, including the right of amendment reserved to Grantor herein and the minimum age requirements of the occupants.

13. Condemnation

13.01. General. This Article shall be deemed to be supplemental to and not in derogation of the provisions of N.J.S.A. 46:8B-25.

13.02. Notice and Participation of Unit Owners. If any building, improvement or Common Element or any part thereof shall be taken, injured or destroyed by eminent domain, each Unit Owner affected shall be entitled to notice of such taking and to participate through the Association in the proceedings incident thereto.

13.03. Allocation of Awards. Any awards made in connection with such proceedings shall be collected by the Association and applied or distributed by it in accordance with Paragraph 5, unless the award or decree provides to the contrary.

If a part of the Common Elements is acquired by eminent domain, the award must be paid to the Association unless the decree provides that the Association shall divide any portion of the award not used for any restoration or repair of the remaining Common Elements among the Unit Owners affected in proportion to their respective damage suffered and their respective percentage interest in the Common Elements before the taking on an equitable basis.

13.04. Re-Allocation Following Condemnation.

(a) Units Rendered Uninhabitable. Upon acquisition by the condemning authority, each affected Unit's entire percentage interest and its corresponding liability for payment of Common Expenses shall be automatically reallocated to the remaining Units on the same basis as their respective percentage interests and Common Expense liability were initially established and the Association shall promptly prepare, execute, and record an amendment to the Master Deed reflecting the reallocations. Any remnant of a Unit which has been rendered uninhabitable remaining after a part of a Unit is taken shall thereafter be a Common Element.

(b) Units Remaining Habitable. Upon acquisition by the condemning authority, the percentage interest and corresponding liability for Common Expenses of each affected Unit shall be that fraction, the numerator of which is the square footage of the Unit remaining after the taking, and the denominator of which is the aggregate square footage of all Units within the Condominium after the taking. The amount by which the percentage of interest and corresponding liability of each affected Unit is reduced shall thereafter be proportionately reallocated to all Units within the Condominium.

14. Insurance

14.01. Insurance. The Board shall obtain and continue in effect blanket property insurance on the Common Elements in an amount equaling replacement value (exclusive of land, foundations or slabs, excavations and such other items as are usually excluded from insurance coverage), and without prejudice to the right of the Owner of any Unit to obtain individual Unit insurance at his own cost. In addition, the Board shall obtain and continue such other amounts of insurance as may be required by the provisions of the By-Laws. Premiums for all such insurance coverage obtained by the Board shall be a Common Expense to be included in the annual common expense assessment.

14.02. Disposition of Insurance Proceeds. If any insured improvements or any part thereof is damaged or destroyed by fire or casualty, the repair, restoration or ultimate disposition of any insurance proceeds shall be in accordance with the provisions in this Paragraph 14.

14.03. Insurance Proceeds Less than or Equal to \$50,000. If the insurance proceeds derived from such loss amount to \$50,000 or less, then the Board shall contract with any licensed contractor or contractors to rebuild or repair such damaged or destroyed portions of the insured improvements in conformance with the original plans and specifications, or if adherence to such original plans and specifications is impracticable in the discretion of the Board, then in conformance with revised plans and specifications provided such repairs or rebuilding shall be of a quality and kind substantially equivalent to the original construction. The Board shall accept bids only in specific amounts and shall not enter into any cost-plus or other sliding scale arrangement for compensation to the contractor.

14.04. Insurance Proceeds Greater than \$50,000. If the insurance proceeds derived from such loss exceed \$50,000, all such insurance proceeds shall be paid directly to an Insurance Trustee as may be designated by the Board, as trustee for all Permitted Mortgage Holders and all Unit Owners as their interests may then appear. Disbursement of such funds shall be made only upon the signatures of a majority of the members of the Board in accordance with the following:

(a) Upon notification of the receipt of insurance proceeds by the Insurance Trustee or at such earlier date as may be determined by the Board, the Board shall enter into a contract for a specific dollar amount with a licensed contractor or contractors for the repair or rebuilding of all of the damaged or destroyed portions of the insured improvements, as nearly as practicable to the original plans and specifications thereof and in accordance with all applicable building codes.

(b) The Board shall enter into said contract with a licensed contractor or contractors which shall have provisions for periodic disbursements of funds by the trustee. Disbursements to the contractor shall be made subject to the prior presentation of an architect's certificate and contractor's requisition containing such provisions as may be appropriate under the circumstances and deemed suitable by the Board.

(c) The Board shall employ a properly qualified party to supervise the repair and rebuilding to insure that such work, services and supplies are of proper quality and that construction is completed in a workmanlike manner and according to plans and specifications.

14.05. Responsibility of Unit Owner. If the damage is only to those parts of a Unit for which the Unit Owner bears the responsibility for payment for and performance of maintenance and repair then that Owner

shall be responsible to bear the costs of and perform the reconstruction and repair, but the proceeds of any insurance on the affected part(s) of the Unit that may have been obtained by the Association shall be made available for such purpose. In all other instances the responsibility of reconstruction and repair after casualty shall be that of the Association.

14.06. Insurance Proceeds Insufficient. If the proceeds of insurance are not sufficient to defray the estimated costs of reconstruction and repair of the affected improvements, or if at any time during or upon completion of reconstruction and repair, the funds for payment of the costs thereof are insufficient, assessments shall be made against all Owners whose Units were damaged or destroyed, in sufficient amounts to provide funds for the payment of such costs. Anything to the contrary in this Master Deed or By-Laws notwithstanding, such assessments shall be in proportion to the Unit Owner's percentage interest in the Common Elements. The foregoing provisions of this subparagraph are applicable to the repairs and reconstruction to be undertaken by the Association and do not cover damages to those portions of the Unit for which the responsibility of maintenance and repair is that of the Unit Owner for which the costs and expenses must be borne by each Owner; provided, however, any portion of the insurance proceeds representing damage for which the responsibility of reconstruction and repair lies with an individual Unit Owner shall be paid to said Unit Owner, or if there is a mortgage endorsement as to such Unit, then to the Unit Owner and mortgagee, jointly.

14.07. Excess Insurance Proceeds. If the amount of available insurance proceeds should exceed the cost of any such reconstruction or repair, the excess shall be retained by the Association and applied by it to reduce the Common Expenses.

14.08. Assignment to Permitted Mortgage Holder. In the event the Association determines not to repair or restore the damaged property in accordance with N.J.S.A. 46:8B-24, any insurance proceeds payable to a Unit Owner as a result of damage or destruction to his Unit and/or interest in the Common Elements are hereby assigned and shall be paid to any appropriate mortgage holder(s) as their interests may appear, for application to the appropriate mortgage indebtedness and the excess, if any, shall be paid to the appropriate Unit Owners, all in accordance with N.J.S.A. 46:8B-24.

15. Protective Provisions for the Benefit of Eligible Mortgage Holders

15.01. General. Anything to the contrary in this Master Deed or the By-Laws or Certificate of Incorporation notwithstanding, the provisions of this Paragraph shall apply with respect to each Eligible Mortgage Holder.

15.02. Notice. Any Eligible Mortgage Holder shall be entitled to timely written notice of:

- (a) any condemnation or casualty loss that affects either a material portion of the Condominium or the Unit securing the Eligible Mortgager Holder's mortgage; and no Unit Owner or other party shall have priority over such Eligible Mortgage Holder with respect to the distribution to such Unit(s) of the proceeds of any condemnation award of settlement in the event of condemnation or with respect to the distribution to such Unit(s) of any insurance proceeds in the event of casualty loss; and
- (b) any sixty (60) day delinquency in the payment of Common Expense assessment installments or other assessments or charges owed to the Association by a Unit Owner of any Unit upon which the Eligible Mortgage Holder holds a mortgage; and
- (c) a lapse, cancellation or material modification of any insurance policy or fidelity bond maintained by the Association; and
- (d) any proposed action that requires the consent of a specified percentage of Eligible Mortgage Holders.

15.03. Amendments Requiring Approval of 51% of Eligible Mortgage Holders. The prior written approval of at least fifty-one percent (51%) of the Eligible Mortgage Holders is required for any material amendment to the Master Deed or to the By-Laws or Certificate of Incorporation including, but not limited to, any amendment which would change any provision relating to:

- (a) voting rights;
- (b) reserves for maintenance, repair and replacement of Common Elements;
- (c) responsibility for maintenance and repairs;
- (d) reallocation of interests in the General or Limited Common Elements or rights to their use;
- (e) boundaries of any Unit;
- (f) convertibility of Units into Common Elements or vice versa;
- (g) expansion or contraction of the Condominium, or the addition, annexation or withdrawal of land to or from the Condominium;

- (h) insurance or fidelity bonds;
- (i) leasing of Units;
- (j) imposition of any restrictions upon a Unit Owner's right to sell or transfer his or her Unit;
- (k) a decision by the Association to establish self-management rather than professional management;
- (l) restoration or repair of the Condominium (after damage, destruction or condemnation) in a manner other than that specified in this Master Deed;
- (m) any action to terminate the legal status of the Condominium as a Condominium after substantial damage or condemnation occurs; or
- (n) any provisions that expressly benefit Eligible Mortgage Holders.

15.04. Amendments Requiring Approval of 67% of Eligible Mortgage Holders. The prior written approval of at least sixty-seven percent (67%) of the Eligible Mortgage Holders is required before the effectuation of any decision by the Unit Owners to terminate the legal status of the Condominium as a Condominium for reasons other than substantial destruction or condemnation of the Property.

15.05. Approval of Non-Material Amendment. Any Eligible Mortgage Holder who requests same shall be entitled to receive thirty (30) days advance notice from the Association of any proposed non-material amendment to the Master Deed, the By-Laws or the Certificate of Incorporation permitted by same, which notice shall include a copy of the proposed change; and any Eligible Mortgage Holder shall be deemed to have implicitly approved such change as proposed unless it states in a written response to the Association its objections or comments relative to such proposed change.

15.06. No Partition. No Unit in the Condominium may be partitioned or subdivided without the prior written approval of any Eligible Mortgage Holder for such Unit.

15.07. Common Expense Lien Subordinate. Any lien the Association may have on any Unit in the Condominium for the payment of Common Expense assessments attributable to each Unit is subordinate to the lien or equivalent security interest of any first mortgage on the Unit recorded prior to the date any such Common Expense assessment became due.

15.08. Inspection of Records. Any Eligible Mortgage Holder shall upon request, (a) be permitted to inspect the books and records of

the Association during normal business hours; and (b) receive an annual audited financial statement of the Association within ninety (90) days following the end of any fiscal year of the Association. The Association shall maintain current copies of the Master Deed, Certificate of Incorporation, By-Laws and Rules and Regulations, and any respective amendments thereto.

15.09. Notice of Meetings. Any Eligible Mortgage Holder shall receive written notice of all meetings of the Association and be permitted to designate a representative to attend all such meetings.

15.10. Liability for Common Expense Assessments. Any Permitted Mortgage Holder holding a first mortgage lien on a Unit that obtains title to the Unit as a result of foreclosure of the first mortgage, or by deed or assignment in lieu of foreclosure, or any purchaser in a foreclosure sale, or their respective successors and assigns, is not liable for the share of Common Expenses or other assessments by the Association pertaining to such Unit or chargeable to the former Unit Owner which became due prior to acquisition of title. Such unpaid share of Common Expenses and other assessments shall be deemed to be Common Expenses collectible from all of the remaining Unit Owners including such acquirer, his successors and assigns.

15.11. Management Agreements. Any management agreement for the Condominium will be terminable by the Association with or without cause upon thirty (30) days prior written notice thereof, and the term of any such agreement shall not exceed one (1) year.

15.12. Common Expense Default. Notwithstanding the absence of any express provision to such effect in the mortgage instrument, in the event that there is any default in the payment of any installment of a Common Expense assessment with respect to any Unit, either regular or special, the Permitted Mortgage Holder of such Unit shall be entitled to declare such mortgage in default in the same manner that is permitted by such mortgage with respect to any default in the payment of real estate taxes.

16. Termination

Notwithstanding anything to the contrary herein, an amendment, deed of revocation, or other document shall be effective to terminate the Condominium form of ownership upon the written approval of eighty (80%) percent in interest of all non-Sponsor Unit Owners, and the written approval of the Sponsor for so long as it holds one (1) Unit for sale in the ordinary course of business.

17. Validity

The invalidity of any provision of this Master Deed, the Certificate of Incorporation, or By-Laws of the Association shall not be deemed to impair or affect in any manner the validity, enforceability or

effect the remainder of this Master Deed or said By-Laws and in such event all of the other provisions of this Master Deed and said By-Laws shall continue in full force as if such invalid provisions had never been included.

18. Waiver

No provision contained in this Master Deed shall be deemed to have abrogated or waived by reason of any failure to enforce the same, irrespective of the number of violations or breaches which may occur.

19. Gender

The use of the masculine gender in this Master Deed shall be deemed to refer to the feminine gender and the use of the singular shall be deemed to refer to the plural, and vice versa, whenever the context so requires.

20. Rule Against Perpetuities

If any provision of this Master Deed, or the By-Laws shall be interpreted to constitute a violation of the rule against perpetuities, then such provision shall be deemed to remain in effect until the death of the last survivor of the now living descendants of Robert F. Kennedy, deceased, former Senator of the State of New York, plus twenty one (21) years thereafter.

21. Exhibits attached hereto and made a part hereof are the following:

Exhibit A -
Metes and Bounds Description

Exhibit B -
Stuart Village, Survey and Easements Plan
Stuart Village, Building Location Plan

Exhibit C -
Architectural Drawings

Exhibit D -
Certificate of Incorporation

Exhibit E - By-Laws of Clearbrook Stuart Village
Condominium Association No. 18-A, Inc.

Exhibit F -
Percentage of Interest Schedule

Exhibit G -
Articles of Incorporation of Clearbrook Community
Association

Exhibit H -
By-Laws of Clearbrook Community Association, dated
October 24, 1972.

IN WITNESS WHEREOF, the Sponsor, Clearbrook Partners, L.P., a New Jersey limited partnership, has executed this Master Deed on the date and year first above written.

CLEARBROOK PARTNERS, L.P., a New Jersey limited partnership, General Partner

(SEAL)

By: Castle at Clearbrook, Inc., a New Jersey corporation, General Partner

ATTEST:

By: Leonard Kohl
Leonard Kohl, President

Kenneth A. Simons
KENNETH A. SIMONS

STATE OF NEW JERSEY)
)ss.:
COUNTY OF *Middlesex*)

BE IT REMEMBERED, that on this 21st day of March, 1989, before me the subscriber, an officer duly authorized pursuant to N.J.S.A. 46:14-6, personally appeared KENNETH A. SIMMONS, who, being by me duly sworn on his oath, deposes and makes proof to my satisfaction that he is the ASSISTANT SECRETARY of Castle at Clearbrook, Inc., the Corporation named in the within Instrument which is the general partner of Clearbrook Partners, L.P.; that Leonard Kohl is the President of said Corporation; that the execution, as well as the making of this Instrument, has been duly authorized by a proper resolution of the Board of Directors of said Corporation; that deponent well knows the corporate seal of said Corporation; and the seal affixed to said Instrument is the proper corporate Seal and was thereto affixed and said Instrument signed and delivered by said President as and for the voluntary act and deed of said Corporation and the partnership, in presence of deponent, who thereupon subscribed his name thereto as attesting witness.

Sworn to and Subscribed
before me, the date
aforesaid.

A Notary Public of the
State of New Jersey

LOIS A. LAWLEY
NOTARY PUBLIC OF NEW JERSEY
My Commission Expires Sept. 22, 1993

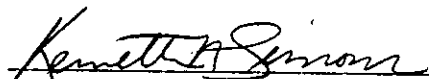

KENNETH A. SIMMONS

EXHIBIT 1A
METES AND BOUNDS DESCRIPTION
OF
CONDOMINIUM

LYNCH, CARMODY, GIULIANO & KAROL, P.A.

CONSULTING ENGINEERS • LAND PLANNERS • SURVEYORS • LANDSCAPE ARCHITECTS

Registered Professional Staff:

Thomas F. Lynch
Cornelius P. Carmody (1970-1984)
Michael J. Giuliano, Jr.
John D. Karol
Donald M. Abbott
Brian S. Flannery
Thomas R. Hansen
Martin G. Miller, III
R. Niels Sperling
William Voeltz
Lee Webb

File No. 0199-1.18A

April 21, 1987
Page 1 of 3
Rev. 11/30/87

Description of Property Clearbrook, Section 18A

The following is a description of property in Monroe Township, Middlesex County, New Jersey. Said property being known and designated as Section 18A of the subdivision of Clearbrook. Also known as Lot 12.06 and part of Lot 8.09 in Block 26 as shown on the Monroe Township Map.

BEGINNING at a point, said point being the most southeasterly corner of Lot 110, Block 26 as shown on the tract map for Clearbrook Section 15, and running thence

1. Along the easterly line of Ardmore Road (Lot 110, Block 26 Section 15) N. 17 36' 52" W. 45.00 feet to a point; thence
2. N. 72 23' 08" E. 116.99 feet to a point; thence
3. N. 68 37' 48" W. 36.01 feet to a point; thence
4. N. 17 36' 52" W. 135.83 feet to a point; thence
5. N. 18 26' 08" E. 64.15 feet to a point; thence
6. N. 13 08' 02" W. 21.53 feet to a point; thence
7. N. 87 50' 06" E. 74.12 feet to a point; thence
8. S. 02 09' 54" E. 25.00 feet to a point; thence
9. N. 87 50' 06" E. 60.00 feet to a point; thence
10. N. 02 09' 54" W. 119.50 feet to a point; thence
11. N. 87 50' 06" E. 130.00 feet to a point; thence

Description
Clearbrook, Section 13A
April 21, 1987
Page 2 of 3

12. S. 02 09' 54" E. 56.84 feet to a point; thence
13. N. 81 31' 42" E. 175.27 feet to a point; thence
14. N. 08 28' 18" W. 8.00 feet to a point; thence
15. N. 81 31' 42" E. 91.99 feet to a point; thence
16. S. 84 06' 09" E. 171.98 feet to a point; thence
17. S. 67 12' 24" E. 122.00 feet to a point in the easterly line of Ardmore Road, being the southeasterly corner of Lot 122 in Block 26 (Section 17); thence
18. S. 22 47' 36" W. 96.50 feet to a point of curvature; thence
19. Southeasterly along a curve to the left having a radius of 24.50 feet, an arc length of 38.48 feet, a chord bearing of S. 22 12' 24" E. and a chord length of 34.65 feet to a point of tangency; thence
20. S. 67 12' 24" E. 133.07 feet to a point of curvature; thence
21. Southeasterly along a curve to the right having a radius of 145.00 feet, an arc length of 165.21 feet, a chord bearing of S. 34 33' 55" E. and a chord length of 156.42 feet to a point of tangency; thence
22. S. 01 55' 27" E. 29.26 feet to a point; thence
23. N. 88 04' 33" E. 15.00 feet to a point; thence
24. S. 01 55' 27" E. 525.15 feet to a point in the northerly line of Cranbury Station-Union Valley Road; thence
25. Along the northerly line of Cranbury Station-Union Valley Road S. 65 15' 23" W. 827.46 feet to a point; thence
26. N. 24 44' 37" W. 327.55 feet to a point; thence
27. S. 65 15' 45" W. 249.91 feet to a point; thence
28. S. 24 44' 37" E. 325.31 feet to a point in the northerly line of Cranbury Station-Union Valley Road; thence
29. Along the northerly line of Cranbury Station-Union Valley Road S. 66 09' 54" W. 138.11 feet to a point of curvature; thence

Description
Clearbrook, Section 18A
April 21, 1987
Page 3 of 3

30. Westerly along a curve to the right, having a radius of 556.00, an arc length of 613.83 feet, a chord bearing of N. 82° 12' 28" W. and a chord length of 583.12 feet to a point of tangency; thence
31. Still along the northerly line of Cranbury Station-Union Valley Road N. 50° 34' 49" W. 215.47 feet to a point; thence
32. N. 53° 59' 24" E. 36.29 feet to a point; thence
33. N. 72° 22' 44" E. 137.16 feet to a point; thence
34. N. 02° 22' 26" W. 475.20 feet to a point; thence
35. N. 03° 24' 24" W. 583.00 feet to a point; thence
36. N. 35° 12' 16" W. 489.07 feet to a point; thence
37. S. 85° 09' 54" E. 320.92 feet to a point; thence
38. S. 13° 15' 48" E. 615.74 feet to a point; thence
39. Due east 320.00 feet to a point; thence
40. S. 45° 00' 00" E., 56.57 feet to a point; thence
41. Due south 85.06 feet to a point; thence
42. N. 72° 23' 08" E. 143.18 feet to a point in the easterly line of Ardmore Road, also being the most southeasterly corner of Lot 110, Block 26 said point also being the point and place of BEGINNING

Contains 43.36 Ac.

The above tract is now known as part of Lot 9.01 in Block 26 on the Tax Map of the Township of Monroe.

AT/CS/bb

Rev. 11/30/87 CB

EXHIBIT 1B
SURVEY AND EASEMENT PLAN
BUILDING LOCATION PLAN

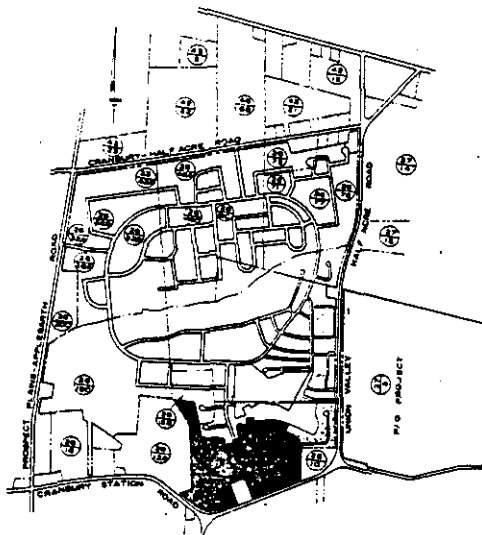

I HEREBY CERTIFY THAT THIS MAP WAS BEEN PREPARED UNDER SUPERVISION
[Signature]
 JOHN B. HARRIS, P.E. No. 13948

I HEREBY CERTIFY THAT THIS PLAN CONSTITUTES A MAP OF THE PROJECT AS SUBMITTED TO THE BOARD OF SUPERVISORS OF CLEARBROOK TOWNSHIP, NEW JERSEY, JULY 11, 1983.

I HEREBY CERTIFY THAT WE ARE THE RECORD HOLDERS OF TITLE TO THE LANDS DEPICTED ON THIS MAP.
 GUARDIAN DEVELOPMENT CORPORATION

NOTES:

ALL DIMENSIONS ARE COORDINATE DIMENSIONS WITH THE EXCEPTION OF THE CONSTRUCTION UNIT.
 NORMAL CONSTRUCTION PRACTICES MAY BE USED IN THE CONSTRUCTION OF THIS PROJECT.
 DIMENSIONS SHOWN ON THIS MAP ARE TO BE MAINTAINED.

LEGEND:

- BUILDING NUMBER INDICATES STREET ADDRESS
- UNIT TYPE (UNIT A THROUGH UNIT G)
- UNIT DESIGNATION (UNIT A THROUGH UNIT G)
- INDICATES BEGINNING OF CONSTRUCTION



AREA MAP

| | | | | | | | | | | | | | | | | | | | | | | | | | | | | | | | | | | | | | | | | | | | | | | | | | | | | | | | | | | | | | | | | | | | | | | | | | | | | | | | | | | | | | | | | | | | | | | | | | | | |
|---|---|---|---|---|---|---|---|---|----|----|----|----|----|----|----|----|----|----|----|----|----|----|----|----|----|----|----|----|----|----|----|----|----|----|----|----|----|----|----|----|----|----|----|----|----|----|----|----|----|----|----|----|----|----|----|----|----|----|----|----|----|----|----|----|----|----|----|----|----|----|----|----|----|----|----|----|----|----|----|----|----|----|----|----|----|----|----|----|----|----|----|----|----|----|----|----|----|----|-----|
| 1 | 2 | 3 | 4 | 5 | 6 | 7 | 8 | 9 | 10 | 11 | 12 | 13 | 14 | 15 | 16 | 17 | 18 | 19 | 20 | 21 | 22 | 23 | 24 | 25 | 26 | 27 | 28 | 29 | 30 | 31 | 32 | 33 | 34 | 35 | 36 | 37 | 38 | 39 | 40 | 41 | 42 | 43 | 44 | 45 | 46 | 47 | 48 | 49 | 50 | 51 | 52 | 53 | 54 | 55 | 56 | 57 | 58 | 59 | 60 | 61 | 62 | 63 | 64 | 65 | 66 | 67 | 68 | 69 | 70 | 71 | 72 | 73 | 74 | 75 | 76 | 77 | 78 | 79 | 80 | 81 | 82 | 83 | 84 | 85 | 86 | 87 | 88 | 89 | 90 | 91 | 92 | 93 | 94 | 95 | 96 | 97 | 98 | 99 | 100 |
|---|---|---|---|---|---|---|---|---|----|----|----|----|----|----|----|----|----|----|----|----|----|----|----|----|----|----|----|----|----|----|----|----|----|----|----|----|----|----|----|----|----|----|----|----|----|----|----|----|----|----|----|----|----|----|----|----|----|----|----|----|----|----|----|----|----|----|----|----|----|----|----|----|----|----|----|----|----|----|----|----|----|----|----|----|----|----|----|----|----|----|----|----|----|----|----|----|----|----|-----|

LYNCH, CARMODY, GIULIANO & KAROL, P.A.
 CONSULTING ENGINEERS
 1000 PINE STREET
 PHILADELPHIA, PA. 19107
 PROJECT NO. 83-001
 DRAWING NO. 100
 DATE: 7/11/83
 SCALE: AS SHOWN
 SHEET NO. 1 OF 1

STUART VILLAGE BUILDING LOCATION PLAN

BRIAN S. FLANNERY
 PROFESSIONAL ENGINEER
 1000 PINE STREET
 PHILADELPHIA, PA. 19107
 PROJECT NO. 83-001
 DRAWING NO. 100
 DATE: 7/11/83
 SCALE: AS SHOWN
 SHEET NO. 1 OF 1

CLEARBROOK
 GUARDIAN DEVELOPMENT CORPORATION
 MUNROE TOWNSHIP, MIDDLESEX COUNTY, NEW JERSEY

PROSPECTIVE NOTICE ARCHITECTURAL DRAWINGS
 THESE DRAWINGS ARE PRELIMINARY AND NOT TO BE USED FOR CONSTRUCTION WITHOUT THE WRITTEN CONSENT OF THE ARCHITECT. ANY REVISIONS TO THESE DRAWINGS SHALL BE MADE BY THE ARCHITECT AND SHALL BE INDICATED BY A REVISION SYMBOL. THE ARCHITECT SHALL BE RESPONSIBLE FOR THE ACCURACY OF THESE DRAWINGS. THE ARCHITECT SHALL NOT BE RESPONSIBLE FOR THE ACCURACY OF ANY INFORMATION OBTAINED FROM THESE DRAWINGS. THE ARCHITECT SHALL NOT BE RESPONSIBLE FOR THE ACCURACY OF ANY INFORMATION OBTAINED FROM THESE DRAWINGS. THE ARCHITECT SHALL NOT BE RESPONSIBLE FOR THE ACCURACY OF ANY INFORMATION OBTAINED FROM THESE DRAWINGS.

EXHIBIT 1C
ARCHITECTURAL DRAWINGS

CLEARBROOK

MONROE TOWNSHIP

NEW JERSEY

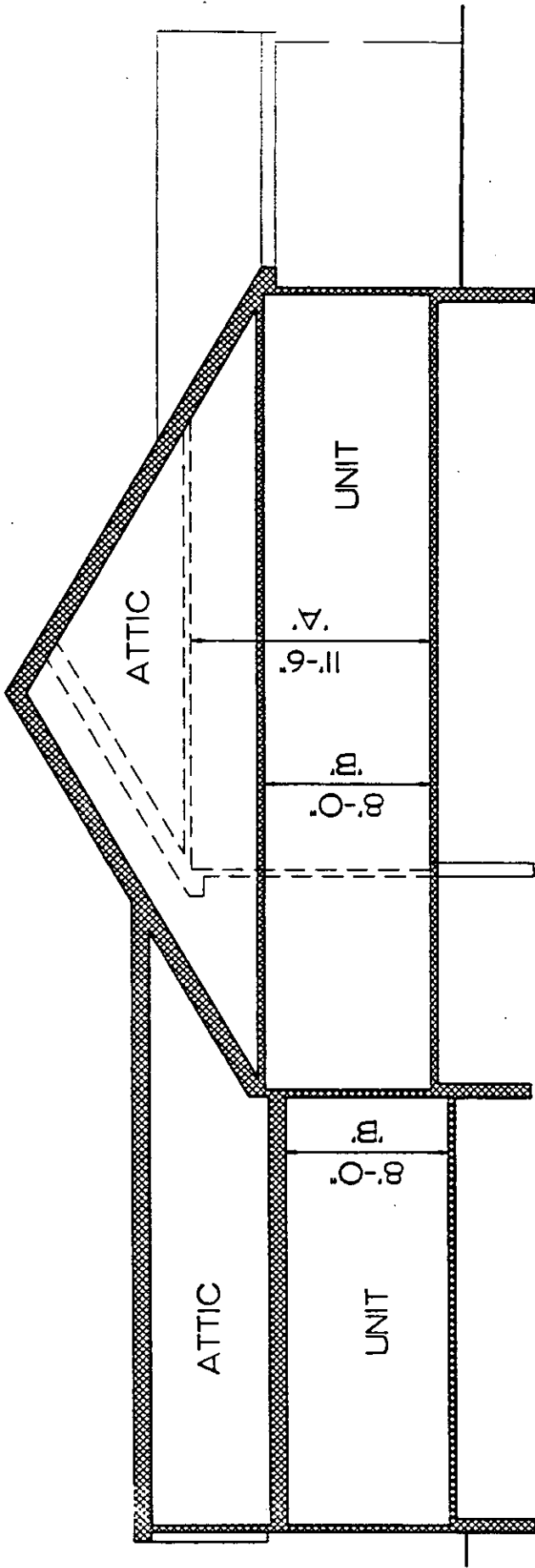

DRAWINGS AND DIMENSIONS ARE APPROXIMATE ONLY. NORMAL CONSTRUCTION PRACTICES MAY RESULT IN DIMENSIONAL VARIANCES.

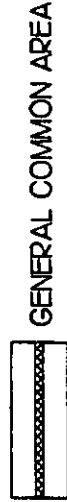

ATTIC SPACE ABOVE UNIT IS GENERAL COMMON AREA AND IS NOT FOR USE BY OWNER.

DIM. 'A' CEILING HEIGHT IN DINING ROOM, LIVINGROOM, AND KITCHEN.

DIM. 'B' CEILING HEIGHT IN BEDROOMS, BATHROOMS, CLOSETS, SOLARIUM, AND GARAGE.

Jerome L. Gruskin, PA

'EMERSON'
MODEL 43X

I CERTIFY THAT THIS PLAN CONSTITUTES A CORRECT REPRESENTATION OF THE IMPROVEMENTS DESCRIBED.

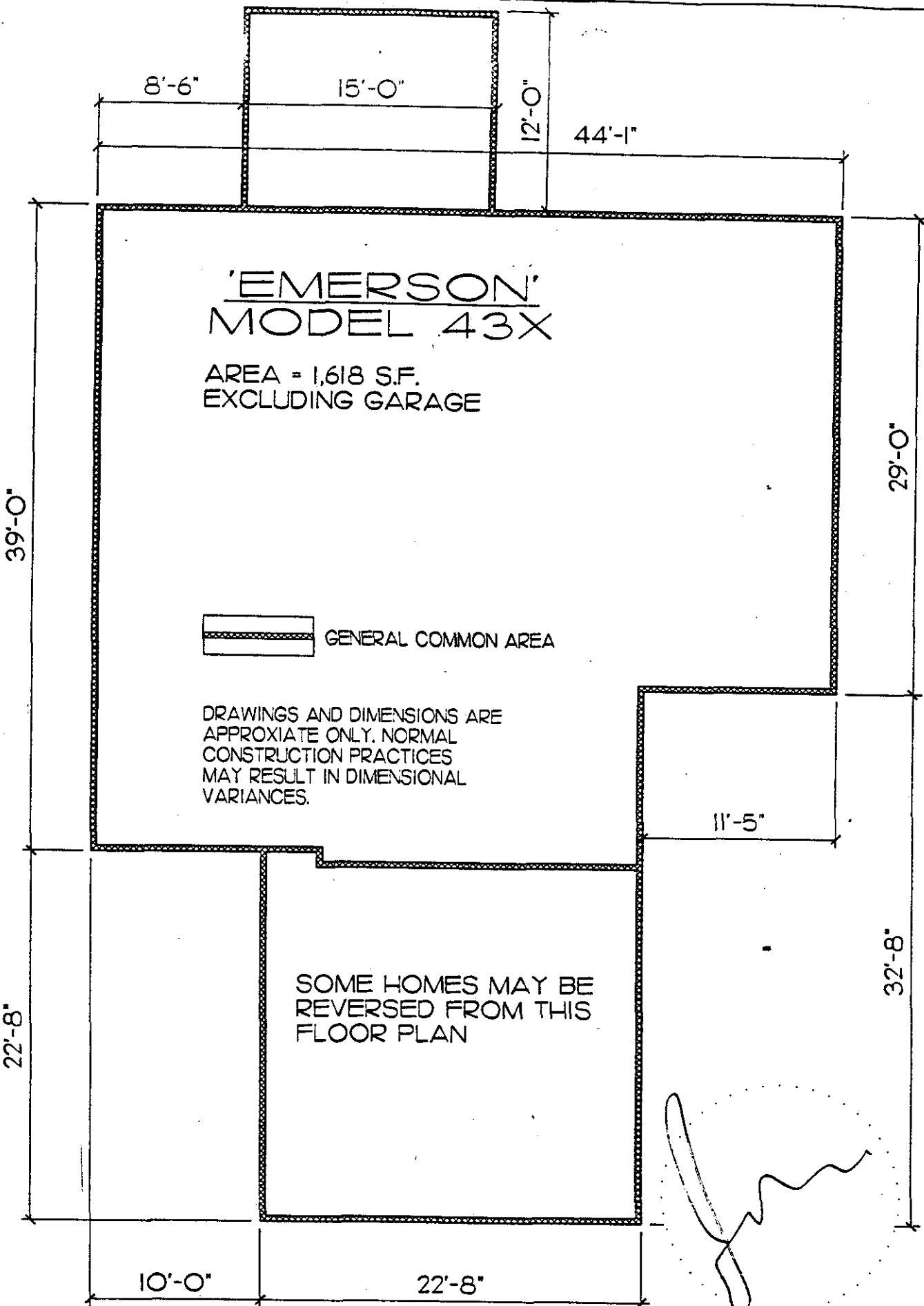

CLEARBROOK

MONROE TOWNSHIP

NEW JERSEY

I CERTIFY THAT THIS PLAN CONSTITUTES A CORRECT REPRESENTATION OF THE IMPROVEMENTS DESCRIBED.

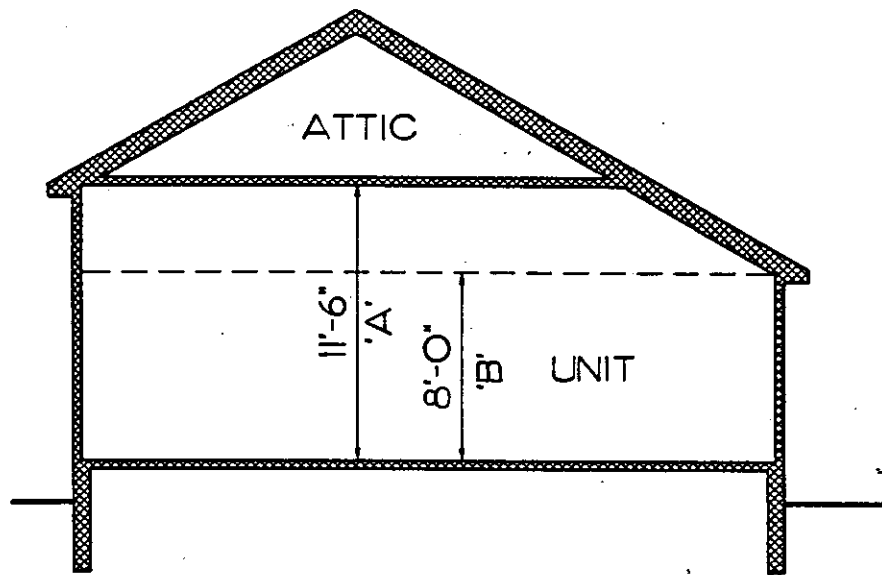

'BRADFORD'
MODEL 43

ATTIC SPACE ABOVE UNIT IS
GENERAL COMMON AREA AND
IS NOT FOR USE BY OWNER.

DRAWINGS AND DIMENSIONS ARE
APPROXIMATE ONLY. NORMAL
CONSTRUCTION PRACTICES
MAY RESULT IN DIMENSIONAL
VARIANCES.

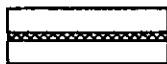

GENERAL COMMON AREA

DIM. 'A' CEILING HEIGHT IN DINING
ROOM, LIVINGROOM, AND
KITCHEN.

DIM. 'B' CEILING HEIGHT IN DINETTE,
BEDROOMS, CLOSETS,
BATHROOMS, SOLARIUM,
AND GARAGE.

A handwritten signature in black ink, enclosed within a faint circular dotted line.

JEROME L. GRUSHKIN, P.A.
ARCHITECTS

CLEARBROOK

MONROE TOWNSHIP

NEW JERSEY

I CERTIFY THAT THIS PLAN CONSTITUTES
A CORRECT REPRESENTATION OF THE
IMPROVEMENTS DESCRIBED.

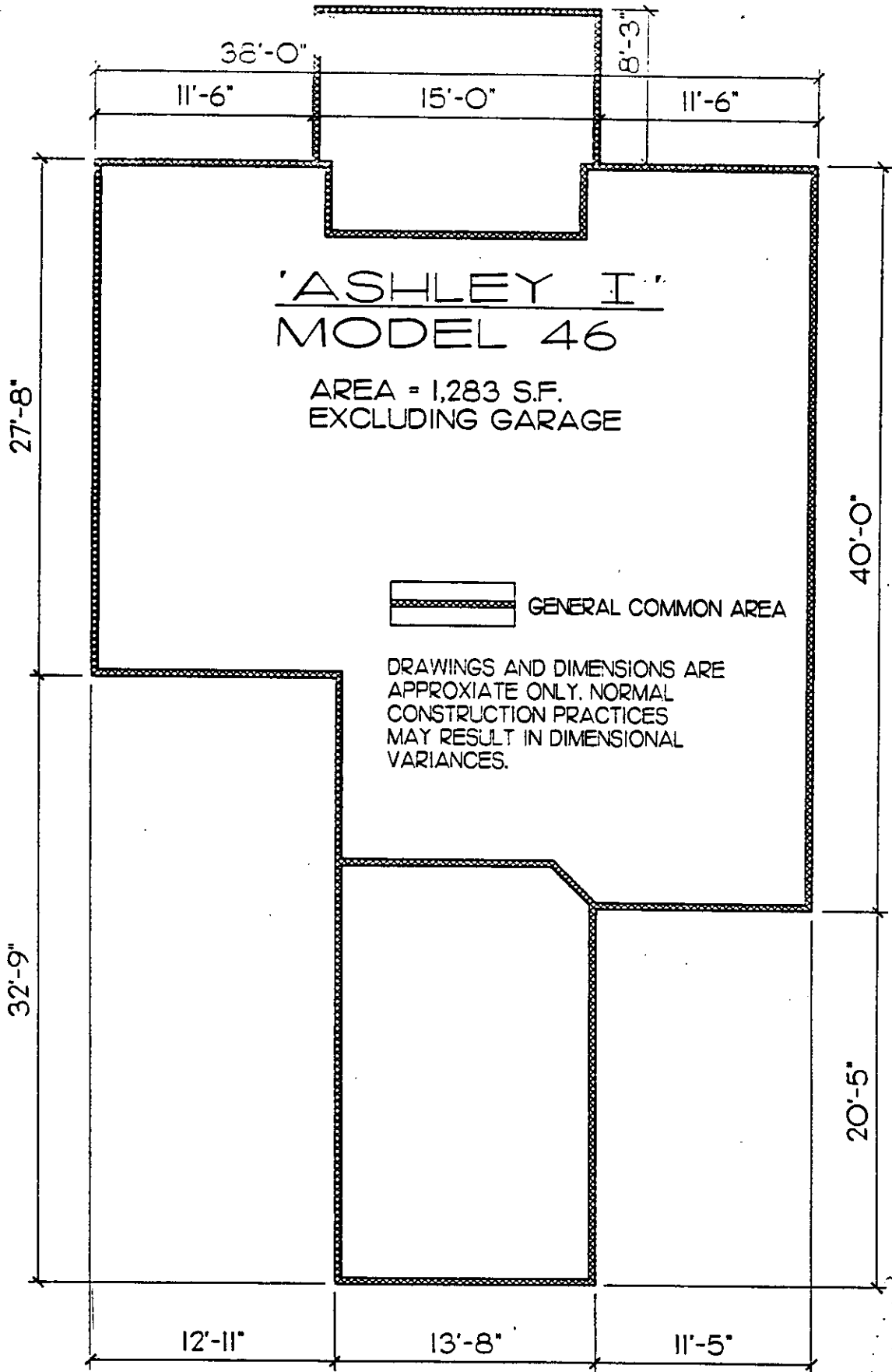

'ASHLEY I'
MODEL 46

AREA = 1,283 S.F.
EXCLUDING GARAGE

 GENERAL COMMON AREA

DRAWINGS AND DIMENSIONS ARE APPROXIMATE ONLY. NORMAL CONSTRUCTION PRACTICES MAY RESULT IN DIMENSIONAL VARIANCES.

SOME HOMES MAY BE REVERSED FROM THIS FLOOR PLAN

CLEARBROOK

MONROE TOWNSHIP

NEW JERSEY

JEROME L. GRUSHKIN, P.A.
ARCHITECTS

I CERTIFY THAT THIS PLAN CONSTITUTES A CORRECT REPRESENTATION OF THE IMPROVEMENTS DESCRIBED.

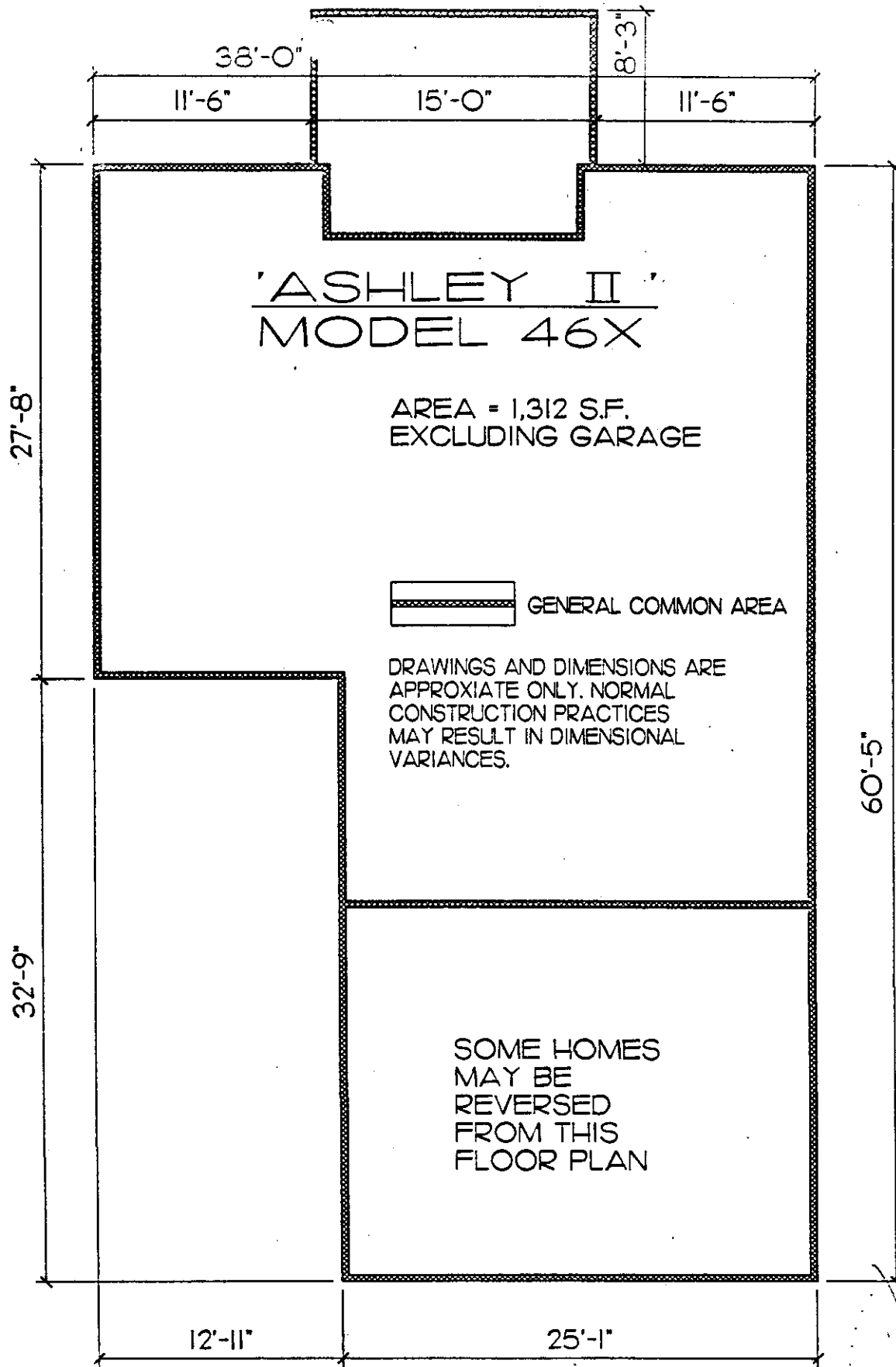

'ASHLEY II'
MODEL 46X

AREA = 1,312 S.F.
EXCLUDING GARAGE

 GENERAL COMMON AREA

DRAWINGS AND DIMENSIONS ARE APPROXIMATE ONLY. NORMAL CONSTRUCTION PRACTICES MAY RESULT IN DIMENSIONAL VARIANCES.

SOME HOMES MAY BE REVERSED FROM THIS FLOOR PLAN

CLEARBROOK

MONROE TOWNSHIP NEW JERSEY

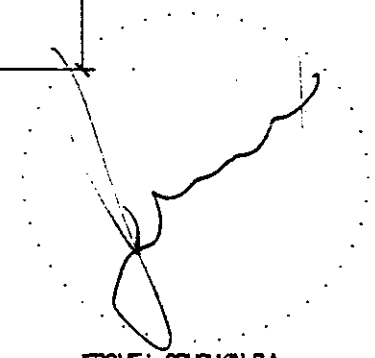

Jerome L. Grushkin, P.A.
ARCHITECTS

I CERTIFY THAT THIS PLAN CONSTITUTES A CORRECT REPRESENTATION OF THE IMPROVEMENTS DESCRIBED.

CLEARBROOK

MONROE TOWNSHIP

NEW JERSEY

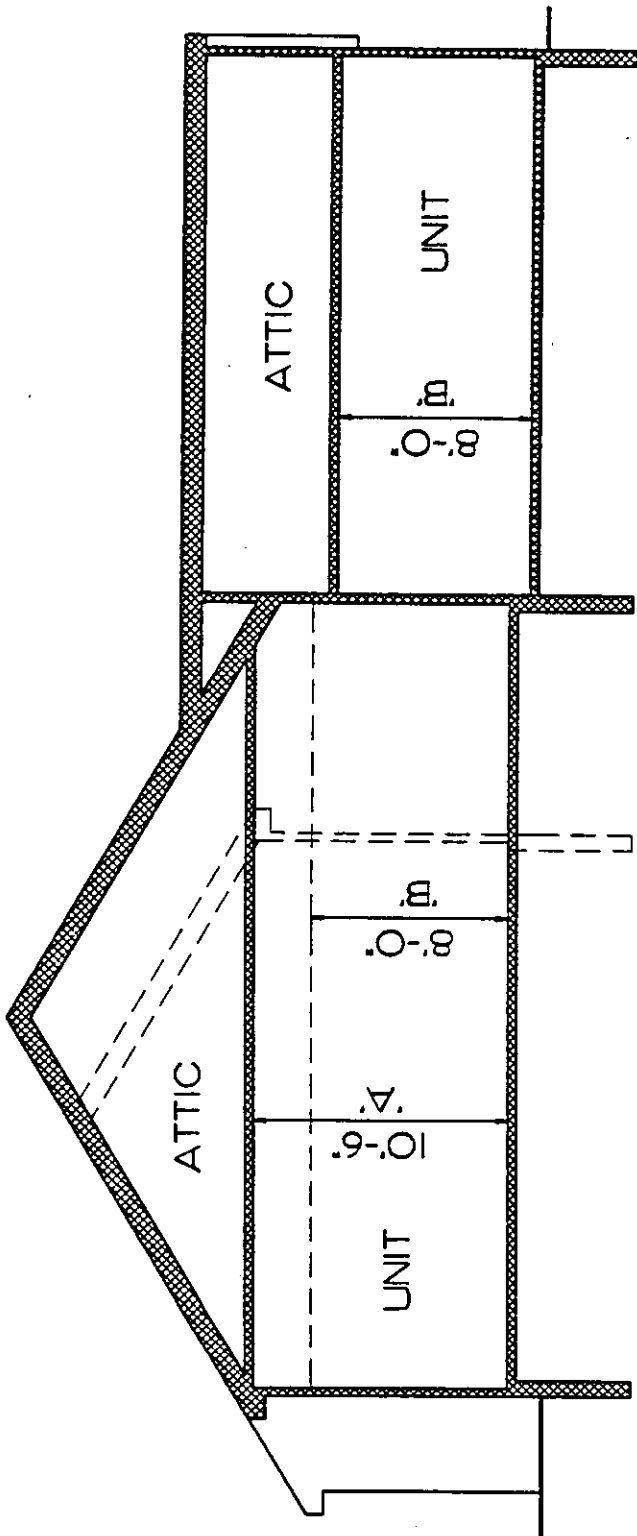

ASHLEY I & II MODEL 46 & 46X

ATTIC SPACE ABOVE UNIT IS
GENERAL COMMON AREA AND
IS NOT FOR USE BY OWNER.

DRAWINGS AND DIMENSIONS ARE
APPROXIMATE ONLY. NORMAL
CONSTRUCTION PRACTICES
MAY RESULT IN DIMENSIONAL
VARIANCES.



Jerome L. Guskis, P.A.
Architect

I CERTIFY THAT THIS PLAN CONSTITUTES
A CORRECT REPRESENTATION OF THE
IMPROVEMENTS DESCRIBED.

DIM. 'A' CEILING HEIGHT IN LIVINGROOM,
DINING ROOM, GUEST BEDROOM,
AND FOYER AREA.

DIM. 'B' CEILING HEIGHT IN MASTER
BEDROOM, BATHROOMS,
KITCHEN, CLOSETS,
SOLARIUM, AND GARAGE.

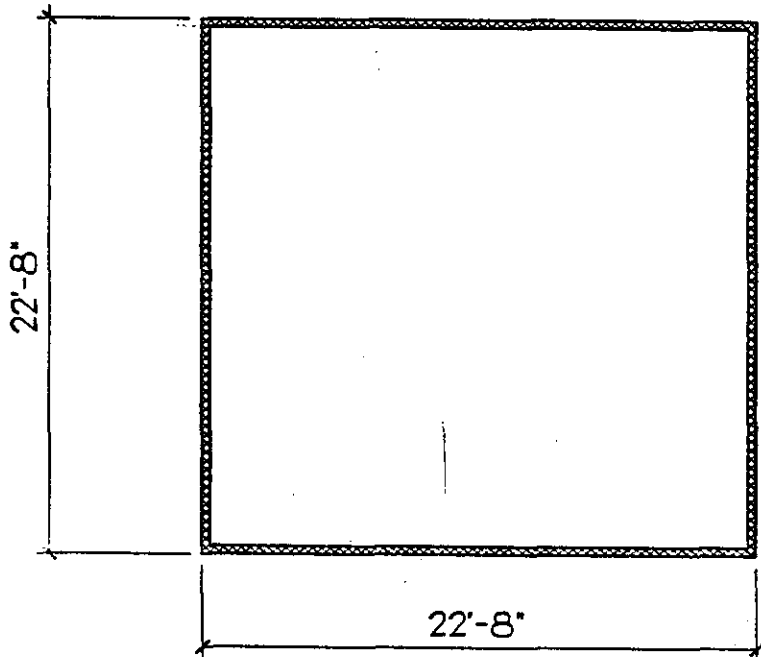
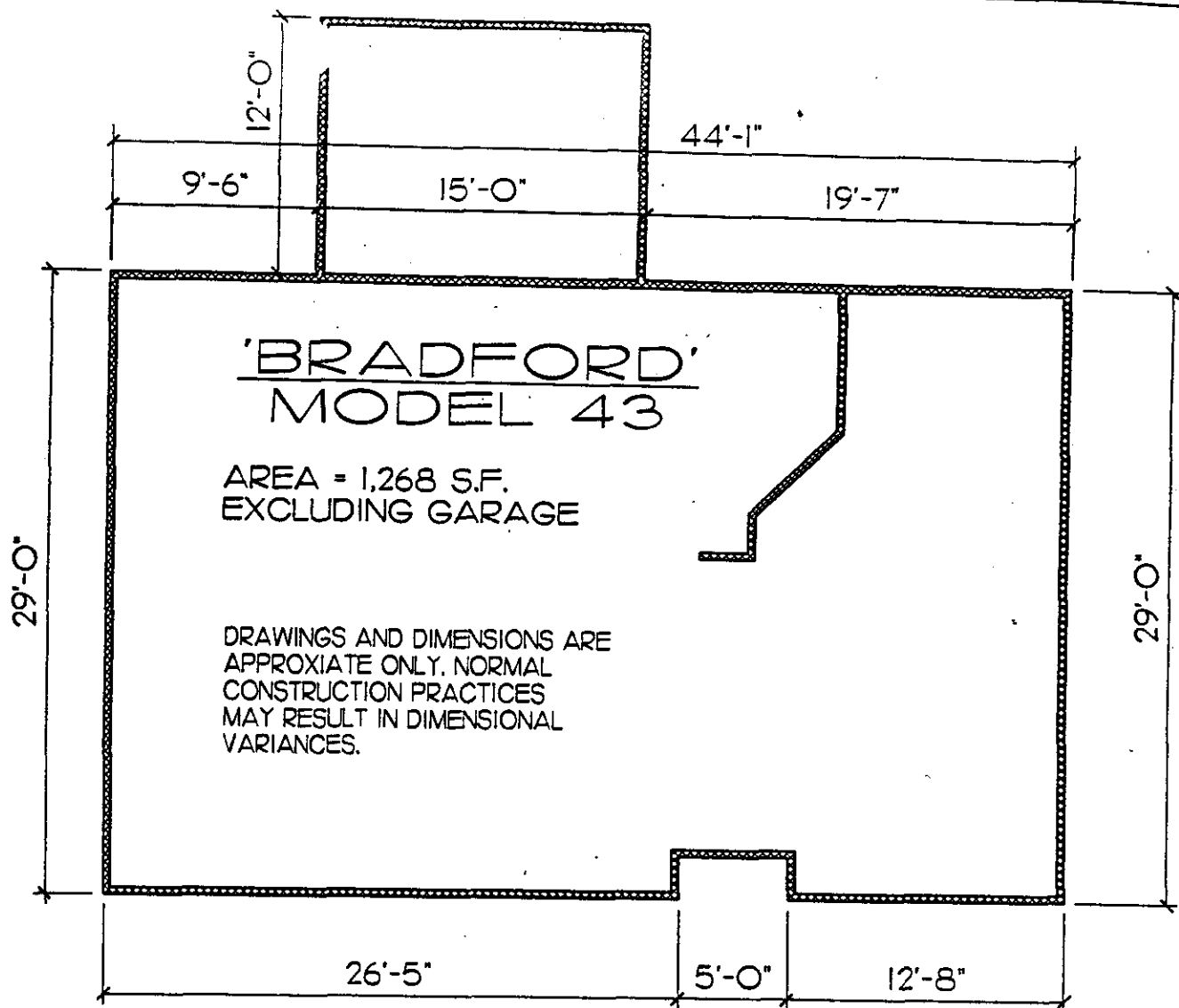

SOME HOMES MAY BE REVERSED FROM THIS FLOOR PLAN

 GENERAL COMMON AREA



Jerome L. Grushkin, P.A.
Architects

CLEARBROOK

MONROE TOWNSHIP NEW JERSEY

I CERTIFY THAT THIS PLAN CONSTITUTES A CORRECT REPRESENTATION OF THE IMPROVEMENTS DESCRIBED.

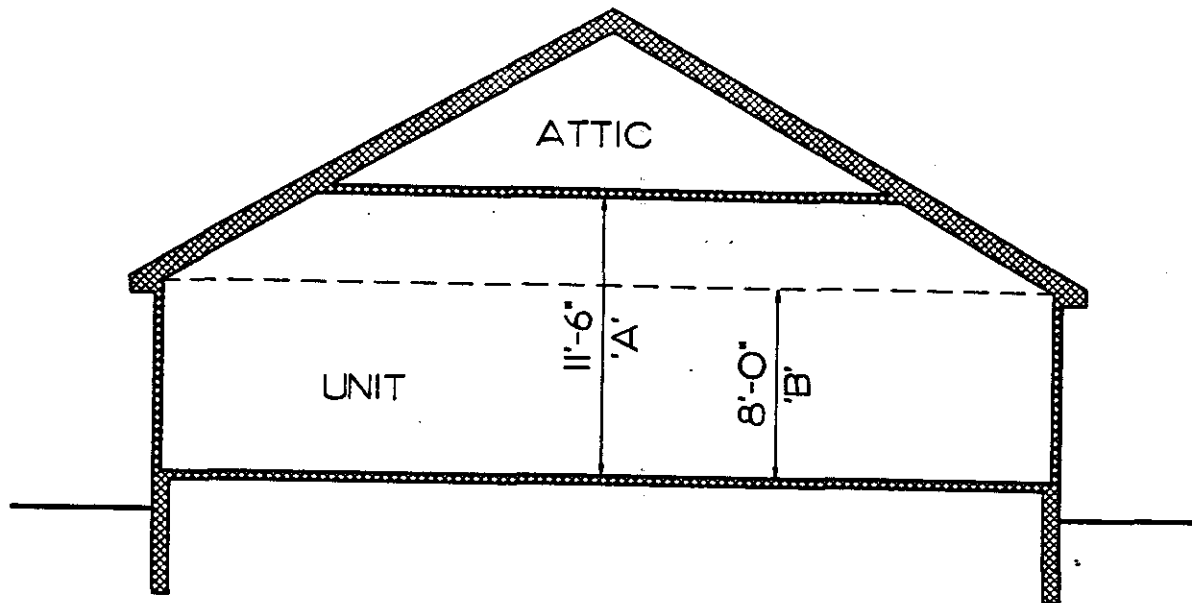

'DEXTER I & II'
MODEL 42 & 42X

ATTIC SPACE ABOVE UNIT IS
GENERAL COMMON AREA AND
IS NOT FOR USE BY OWNER.

DRAWINGS AND DIMENSIONS ARE
APPROXIMATE ONLY. NORMAL
CONSTRUCTION PRACTICES
MAY RESULT IN DIMENSIONAL
VARIANCES.

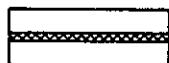

GENERAL COMMON AREA

DIM. 'A' CEILING HEIGHT IN DINING
ROOM, LIVINGROOM, AND
KITCHEN.

DIM. 'B' CEILING HEIGHT IN
BEDROOMS, BATHROOMS,
CLOSETS, SOLARIUM,
AND GARAGE

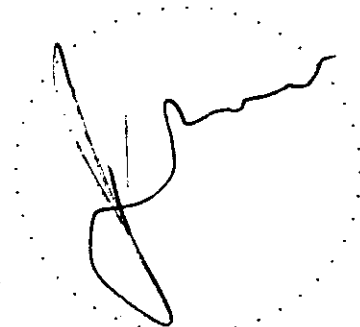

JEROME L. GRUSHKIN, P.A.
ARCHITECTS

CLEARBROOK

MONROE TOWNSHIP

NEW JERSEY

I CERTIFY THAT THIS PLAN CONSTITUTES
A CORRECT REPRESENTATION OF THE
IMPROVEMENTS DESCRIBED.

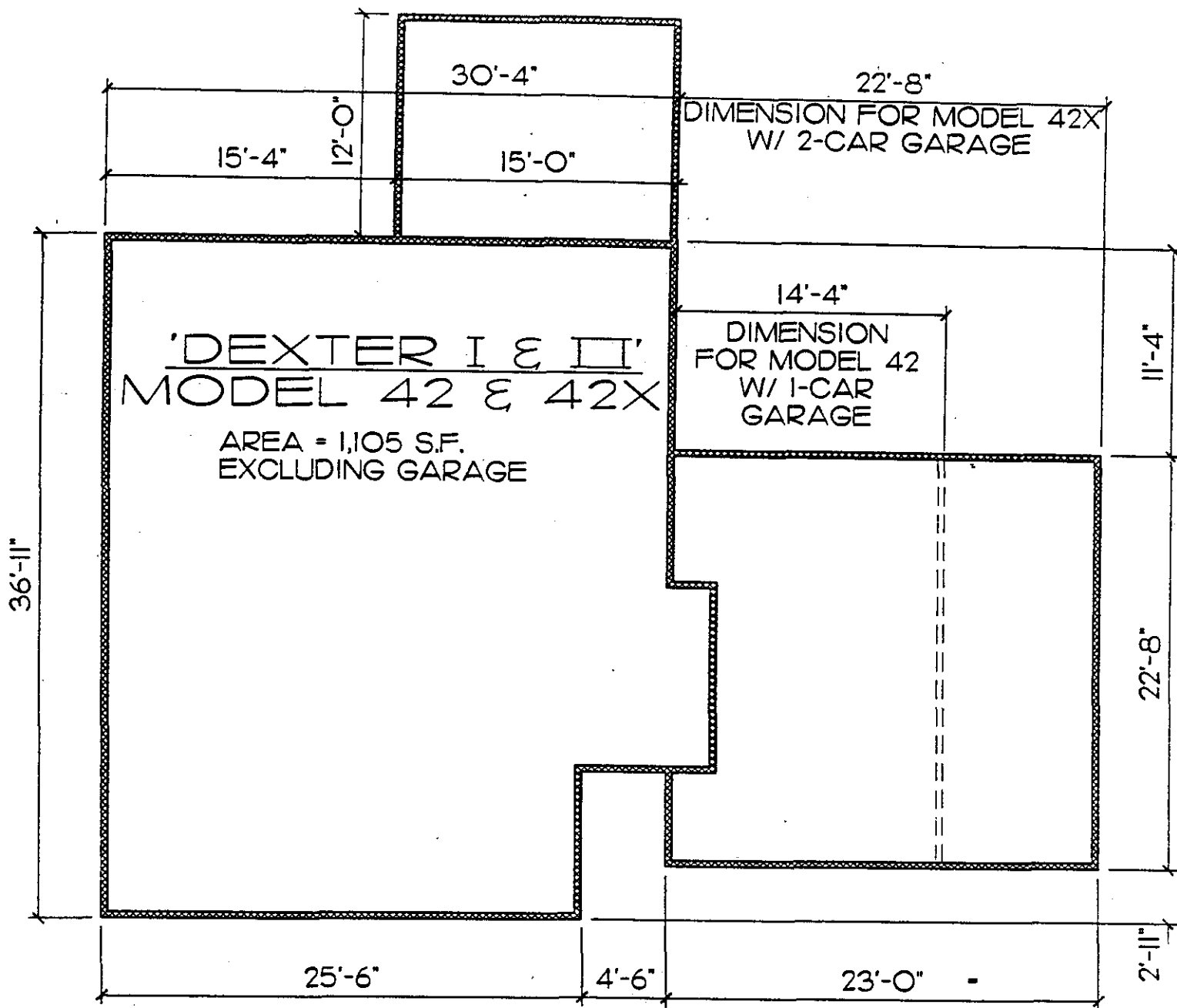

DRAWINGS AND DIMENSIONS ARE APPROXIMATE ONLY. NORMAL CONSTRUCTION PRACTICES MAY RESULT IN DIMENSIONAL VARIANCES.



SOME HOMES MAY BE REVERSED FROM THIS FLOOR PLAN

CLEARBROOK

MONROE TOWNSHIP

NEW JERSEY

Jerome L. Guskis, PA.
ARCHITECTS

I CERTIFY THAT THIS PLAN CONSTITUTES A CORRECT REPRESENTATION OF THE IMPROVEMENTS DESCRIBED.

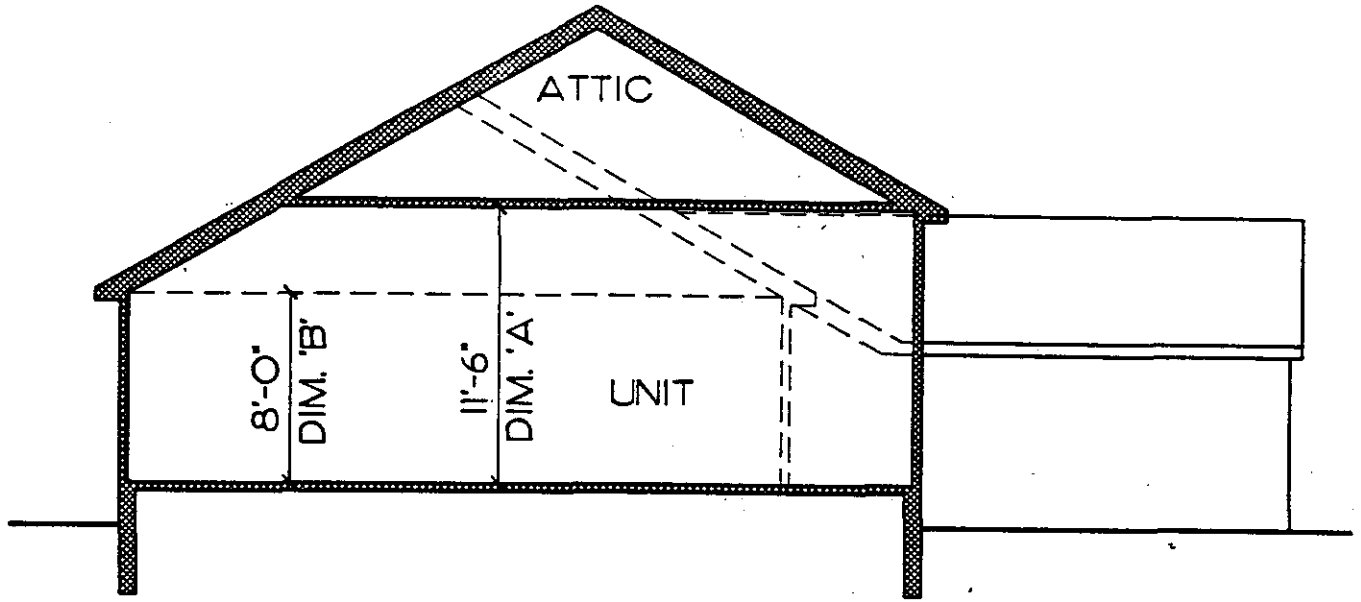

'ESSEX'
MODEL 81

ATTIC SPACE ABOVE UNIT IS
GENERAL COMMON AREA AND
IS NOT FOR USE BY OWNER.

DRAWINGS AND DIMENSIONS ARE
APPROXIMATE ONLY. NORMAL
CONSTRUCTION PRACTICES
MAY RESULT IN DIMENSIONAL
VARIANCES.



DIM. 'A' CEILING HEIGHT IN MASTER
BEDROOM AND GUEST
BEDROOM.

DIM. 'B' CEILING HEIGHT IN LIVINGROOM,
DINING ROOM, KITCHEN, GARAGE,
BATHROOMS, CLOSETS,
AND SOLARIUM

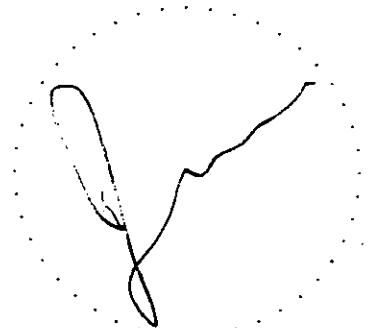

Jerome L. Gluskin, P.A.
ARCHITECTS

CLEARBROOK

MONROE TOWNSHIP

NEW JERSEY

I CERTIFY THAT THIS PLAN CONSTITUTES
A CORRECT REPRESENTATION OF THE
IMPROVEMENTS DESCRIBED.

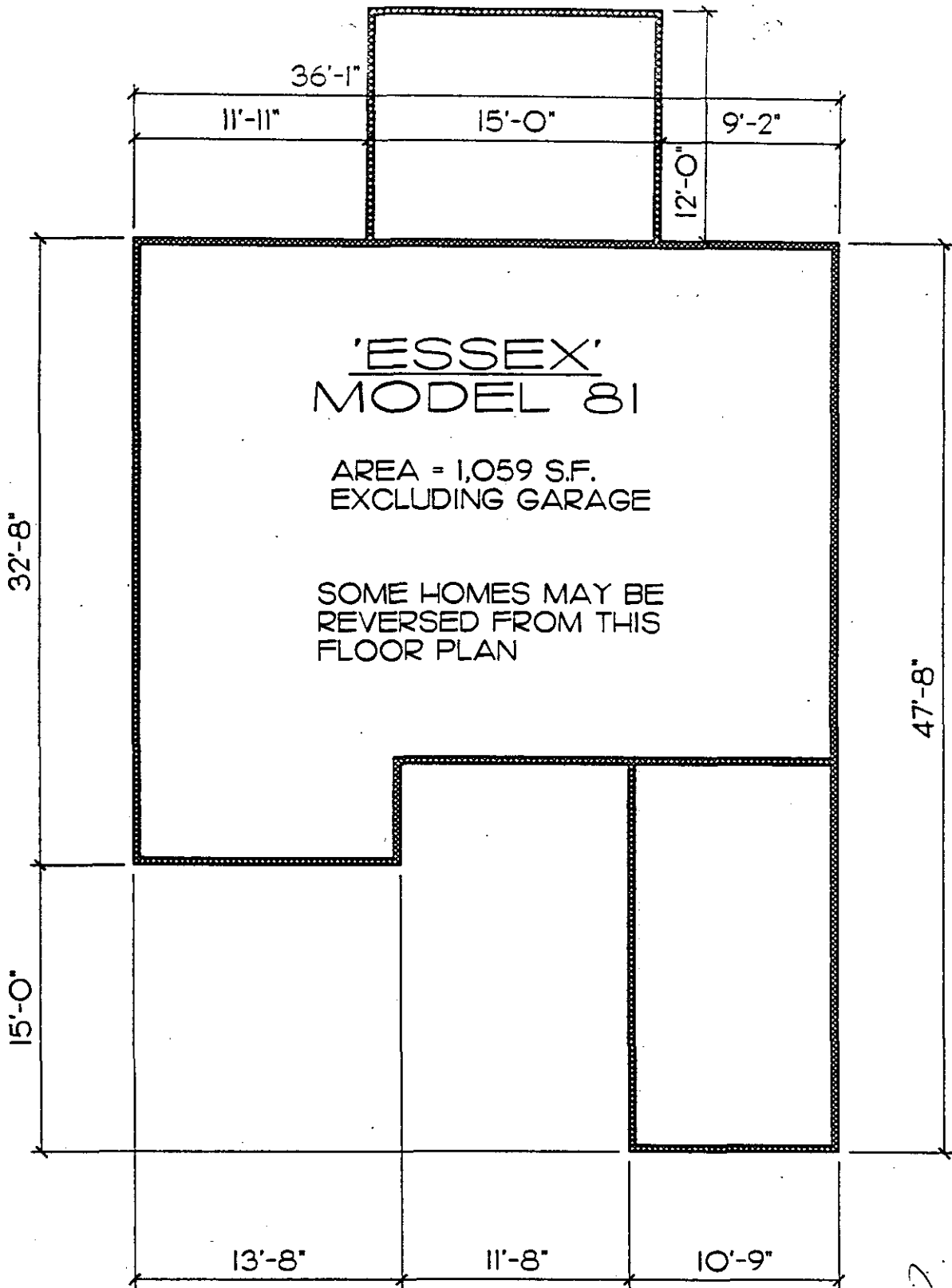

**'ESSEX'
MODEL 81**

AREA = 1,059 S.F.
EXCLUDING GARAGE

SOME HOMES MAY BE
REVERSED FROM THIS
FLOOR PLAN



GENERAL COMMON AREA

DRAWINGS AND DIMENSIONS ARE APPROXIMATE ONLY. NORMAL CONSTRUCTION PRACTICES MAY RESULT IN DIMENSIONAL VARIANCES.

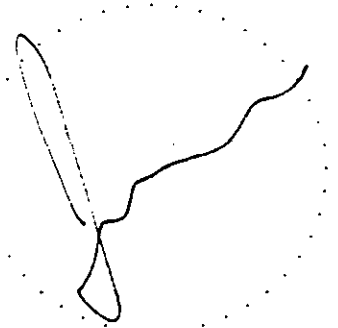

JEROME L. GUSKIS, P.A.
ARCHITECTS

CLEARBROOK

MONROE TOWNSHIP

NEW JERSEY

I CERTIFY THAT THIS PLAN CONSTITUTES A CORRECT REPRESENTATION OF THE IMPROVEMENTS DESCRIBED.

EXHIBIT 1D
CERTIFICATE OF INCORPORATION
OF
CLEARBROOK STUART VILLAGE
CONDOMINIUM ASSOCIATION
NO. 18-A, INC.

EXHIBIT 1-F
SCHEDULE OF PERCENTAGE
OF
INTEREST OF COMMON ELEMENTS

EXHIBIT
 Schedule of Initial Sales Price and
 Percentage (%) of Interest on Common Elements

| Bldg. No. | Apt. Des. | Unit Type | Initial Sales Price | % Int. | Bldg. No. | Apt. Des. | Unit Type | Initial Sales Price | % Int. |
|-----------|-----------|-----------|---------------------|------------|-----------|-----------|-----------|---------------------|------------|
| 556 | A | Ashley II | \$209,900 | 0.7521033% | 574 | C | Bradford | \$207,900 | 0.7449370% |
| 556 | B | Emerson | \$242,900 | 0.8703473% | 575 | A | Ashley II | \$209,900 | 0.7521033% |
| 557 | A | Ashley I | \$197,900 | 0.7091055% | 576 | A | Ashley I | \$197,900 | 0.7091055% |
| 557 | B | Dexter I | \$171,900 | 0.6159436% | 576 | B | Dexter I | \$171,900 | 0.6159436% |
| 557 | C | Emerson | \$242,900 | 0.8703473% | 576 | C | Bradford | \$207,900 | 0.7449370% |
| 558 | A | Ashley II | \$209,900 | 0.7521033% | 576 | D | Ashley II | \$209,900 | 0.7521033% |
| 558 | B | Ashley II | \$209,900 | 0.7521033% | 577 | A | Ashley II | \$209,900 | 0.7521033% |
| 559 | A | Bradford | \$207,900 | 0.7449370% | 577 | B | Dexter I | \$171,900 | 0.6159436% |
| 559 | B | Dexter I | \$171,900 | 0.6159436% | 577 | C | Ashley I | \$197,900 | 0.7091055% |
| 559 | C | Ashley II | \$209,900 | 0.7521033% | 578 | A | Emerson | \$242,900 | 0.8703473% |
| 560 | A | Ashley II | \$209,900 | 0.7521033% | 579 | A | Ashley II | \$209,900 | 0.7521033% |
| 560 | B | Emerson | \$242,900 | 0.8703473% | 579 | B | Bradford | \$207,900 | 0.7449370% |
| 561 | A | Emerson | \$242,900 | 0.8703473% | 579 | C | Dexter I | \$171,900 | 0.6159436% |
| 562 | A | Dexter I | \$171,900 | 0.6159436% | 580 | A | Ashley II | \$209,900 | 0.7521033% |
| 562 | B | Bradford | \$207,900 | 0.7449370% | 580 | B | Ashley II | \$209,900 | 0.7521033% |
| 562 | C | Ashley II | \$209,900 | 0.7521033% | 581 | A | Ashley II | \$209,900 | 0.7521033% |
| 563 | A | Ashley II | \$209,900 | 0.7521033% | 581 | B | Emerson | \$242,900 | 0.8703473% |
| 563 | B | Emerson | \$242,900 | 0.8703473% | 582 | A | Ashley II | \$209,900 | 0.7521033% |
| 564 | A | Ashley II | \$209,900 | 0.7521033% | 582 | B | Dexter I | \$171,900 | 0.6159436% |
| 564 | B | Emerson | \$242,900 | 0.8703473% | 582 | C | Ashley I | \$197,900 | 0.7091055% |
| 565 | A | Bradford | \$207,900 | 0.7449370% | 583 | A | Ashley I | \$197,900 | 0.7091055% |
| 565 | B | Ashley I | \$197,900 | 0.7091055% | 583 | B | Dexter I | \$171,900 | 0.6159436% |
| 565 | C | Emerson | \$242,900 | 0.8703473% | 583 | C | Emerson | \$242,900 | 0.8703473% |
| 566 | A | Ashley II | \$209,900 | 0.7521033% | 584 | A | Ashley II | \$209,900 | 0.7521033% |
| 566 | B | Emerson | \$242,900 | 0.8703473% | 585 | A | Ashley II | \$209,900 | 0.7521033% |
| 567 | A | Ashley II | \$209,900 | 0.7521033% | 585 | B | Emerson | \$242,900 | 0.8703473% |
| 567 | B | Bradford | \$207,900 | 0.7449370% | 586 | A | Ashley II | \$209,900 | 0.7521033% |
| 567 | C | Dexter I | \$171,900 | 0.6159436% | 586 | B | Dexter I | \$171,900 | 0.6159436% |
| 568 | A | Ashley II | \$209,900 | 0.7521033% | 586 | C | Bradford | \$207,900 | 0.7449370% |
| 568 | B | Emerson | \$242,900 | 0.8703473% | 587 | A | Ashley I | \$197,900 | 0.7091055% |
| 569 | A | Ashley II | \$209,900 | 0.7521033% | 587 | B | Dexter I | \$171,900 | 0.6159436% |
| 569 | B | Emerson | \$242,900 | 0.8703473% | 587 | C | Emerson | \$242,900 | 0.8703473% |
| 570 | A | Ashley II | \$209,900 | 0.7521033% | 588 | A | Essex | \$155,900 | 0.5586132% |
| 570 | B | Emerson | \$242,900 | 0.8703473% | 588 | B | Essex | \$155,900 | 0.5586132% |
| 571 | A | Dexter I | \$171,900 | 0.6159436% | 589 | A | Ashley II | \$209,900 | 0.7521033% |
| 571 | B | Ashley I | \$197,900 | 0.7091055% | 589 | B | Bradford | \$207,900 | 0.7449370% |
| 572 | A | Ashley I | \$197,900 | 0.7091055% | 589 | C | Dexter I | \$171,900 | 0.6159436% |
| 572 | B | Dexter I | \$171,900 | 0.6159436% | 589 | D | Ashley I | \$197,900 | 0.7091055% |
| 572 | C | Bradford | \$207,900 | 0.7449370% | 590 | A | Essex | \$155,900 | 0.5586132% |
| 572 | D | Ashley II | \$209,900 | 0.7521033% | 590 | B | Essex | \$155,900 | 0.5586132% |
| 573 | A | Ashley II | \$209,900 | 0.7521033% | 591 | A | Ashley II | \$209,900 | 0.7521033% |
| 573 | B | Dexter I | \$171,900 | 0.6159436% | 592 | A | Ashley II | \$209,900 | 0.7521033% |
| 573 | C | Ashley I | \$197,900 | 0.7091055% | 592 | B | Ashley II | \$209,900 | 0.7521033% |
| 574 | A | Ashley II | \$209,900 | 0.7521033% | 592 | A | Ashley I | \$197,900 | 0.7091055% |
| 574 | B | Dexter I | \$171,900 | 0.6159436% | 602 | B | Dexter I | \$171,900 | 0.6159436% |

EXHIBIT
 Schedule of Initial Sales Price and
 Percentage (%) of Interest on Common Elements

| Bldg. No. | Apt. Des. | Unit Type | Initial Sales Price | % Int. | Bldg. No. | Apt. Des. | Unit Type | Initial Sales Price | % Int. |
|-----------|-----------|-----------|---------------------|------------|-----------|-----------|-----------|---------------------|------------|
| 632 | C | Bradford | \$207,900 | 0.7449370% | 641 | C | Ashley I | \$197,900 | 0.7091055% |
| 632 | D | Ashley II | \$209,900 | 0.7521033% | 642 | A | Emerson | \$242,900 | 0.8703473% |
| 633 | A | Ashley II | \$209,900 | 0.7521033% | 642 | B | Ashley II | \$209,900 | 0.7521033% |
| 633 | B | Dexter II | \$182,900 | 0.6553581% | 643 | A | Emerson | \$242,900 | 0.8703473% |
| 633 | C | Emerson | \$242,900 | 0.8703473% | 644 | A | Emerson | \$242,900 | 0.8703473% |
| 634 | A | Essex | \$155,900 | 0.5586132% | 644 | B | Ashley II | \$209,900 | 0.7521033% |
| 634 | B | Essex | \$155,900 | 0.5586132% | 645 | A | Ashley II | \$209,900 | 0.7521033% |
| 635 | A | Essex | \$155,900 | 0.5586132% | 646 | A | Ashley I | \$197,900 | 0.7091055% |
| 635 | B | Essex | \$155,900 | 0.5586132% | 646 | B | Dexter I | \$171,900 | 0.6159436% |
| 636 | A | Ashley II | \$209,900 | 0.7521033% | 646 | C | Bradford | \$207,900 | 0.7449370% |
| 636 | B | Emerson | \$242,900 | 0.8703473% | 646 | D | Ashley II | \$209,900 | 0.7521033% |
| 637 | A | Ashley II | \$209,900 | 0.7521033% | 647 | A | Ashley II | \$209,900 | 0.7521033% |
| 637 | B | Ashley II | \$209,900 | 0.7521033% | 647 | B | Emerson | \$242,900 | 0.8703473% |
| 638 | A | Ashley II | \$209,900 | 0.7521033% | 648 | A | Emerson | \$242,900 | 0.8703473% |
| 638 | B | Emerson | \$242,900 | 0.8703473% | 649 | A | Ashley I | \$197,900 | 0.7091055% |
| 639 | A | Ashley II | \$209,900 | 0.7521033% | 649 | B | Dexter I | \$171,900 | 0.6159436% |
| 639 | B | Dexter I | \$171,900 | 0.6159436% | 649 | C | Bradford | \$207,900 | 0.7449370% |
| 639 | C | Ashley I | \$197,900 | 0.7091055% | 649 | D | Ashley II | \$209,900 | 0.7521033% |
| 640 | A | Ashley II | \$209,900 | 0.7521033% | 650 | A | Emerson | \$242,900 | 0.8703473% |
| 640 | B | Dexter II | \$182,900 | 0.6553581% | 650 | B | Ashley II | \$209,900 | 0.7521033% |
| 640 | C | Emerson | \$242,900 | 0.8703473% | 651 | A | Ashley II | \$209,900 | 0.7521033% |
| 641 | A | Ashley II | \$209,900 | 0.7521033% | 651 | B | Dexter II | \$182,900 | 0.6553581% |
| 641 | B | Dexter I | \$171,900 | 0.6159436% | 651 | C | Emerson | \$242,900 | 0.8703473% |

EXHIBIT F

EXHIBIT

Schedule of Initial Sales Price and
Percentage (X) of Interest on Common Elements

| Bldg. No. | Apt. Des. | Unit Type | Initial Sales Price | X Int. | Bldg. No. | Apt. Des. | Unit Type | Initial Sales Price | X Int. |
|-----------|-----------|-----------|---------------------|------------|-----------|-----------|-----------|---------------------|------------|
| 556 | A | Ashley II | \$209,900 | 0.7521033X | 574 | C | Bradford | \$207,900 | 0.7449370X |
| 556 | B | Emerson | \$242,900 | 0.8703473X | 575 | A | Ashley II | \$209,900 | 0.7521033X |
| 557 | A | Ashley I | \$197,900 | 0.7091055X | 576 | A | Ashley I | \$197,900 | 0.7091055X |
| 557 | B | Dexter I | \$171,900 | 0.6159436X | 576 | B | Dexter I | \$171,900 | 0.6159436X |
| 557 | C | Emerson | \$242,900 | 0.8703473X | 576 | C | Bradford | \$207,900 | 0.7449370X |
| 558 | A | Ashley II | \$209,900 | 0.7521033X | 576 | D | Ashley II | \$209,900 | 0.7521033X |
| 558 | B | Ashley II | \$209,900 | 0.7521033X | 577 | A | Ashley II | \$209,900 | 0.7521033X |
| 559 | A | Bradford | \$207,900 | 0.7449370X | 577 | B | Dexter I | \$171,900 | 0.6159436X |
| 559 | B | Dexter I | \$171,900 | 0.6159436X | 577 | C | Ashley I | \$197,900 | 0.7091055X |
| 559 | C | Ashley II | \$209,900 | 0.7521033X | 578 | A | Emerson | \$242,900 | 0.8703473X |
| 560 | A | Ashley II | \$209,900 | 0.7521033X | 579 | A | Ashley II | \$209,900 | 0.7521033X |
| 560 | B | Emerson | \$242,900 | 0.8703473X | 579 | B | Bradford | \$207,900 | 0.7449370X |
| 561 | A | Emerson | \$242,900 | 0.8703473X | 579 | C | Dexter I | \$171,900 | 0.6159436X |
| 562 | A | Dexter I | \$171,900 | 0.6159436X | 580 | A | Ashley II | \$209,900 | 0.7521033X |
| 562 | B | Bradford | \$207,900 | 0.7449370X | 580 | B | Ashley II | \$209,900 | 0.7521033X |
| 562 | C | Ashley II | \$209,900 | 0.7521033X | 581 | A | Ashley II | \$209,900 | 0.7521033X |
| 563 | A | Ashley II | \$209,900 | 0.7521033X | 581 | B | Emerson | \$242,900 | 0.8703473X |
| 563 | B | Emerson | \$242,900 | 0.8703473X | 582 | A | Ashley II | \$209,900 | 0.7521033X |
| 564 | A | Ashley II | \$209,900 | 0.7521033X | 582 | B | Dexter I | \$171,900 | 0.6159436X |
| 564 | B | Emerson | \$242,900 | 0.8703473X | 582 | C | Ashley I | \$197,900 | 0.7091055X |
| 565 | A | Bradford | \$207,900 | 0.7449370X | 583 | A | Ashley I | \$197,900 | 0.7091055X |
| 565 | B | Ashley I | \$197,900 | 0.7091055X | 583 | B | Dexter I | \$171,900 | 0.6159436X |
| 565 | C | Emerson | \$242,900 | 0.8703473X | 583 | C | Emerson | \$242,900 | 0.8703473X |
| 566 | A | Ashley II | \$209,900 | 0.7521033X | 584 | A | Ashley II | \$209,900 | 0.7521033X |
| 566 | B | Emerson | \$242,900 | 0.8703473X | 585 | A | Ashley II | \$209,900 | 0.7521033X |
| 567 | A | Ashley II | \$209,900 | 0.7521033X | 585 | B | Emerson | \$242,900 | 0.8703473X |
| 567 | B | Bradford | \$207,900 | 0.7449370X | 586 | A | Ashley II | \$209,900 | 0.7521033X |
| 567 | C | Dexter I | \$171,900 | 0.6159436X | 586 | B | Dexter I | \$171,900 | 0.6159436X |
| 568 | A | Ashley II | \$209,900 | 0.7521033X | 586 | C | Bradford | \$207,900 | 0.7449370X |
| 568 | B | Emerson | \$242,900 | 0.8703473X | 587 | A | Ashley I | \$197,900 | 0.7091055X |
| 569A | A | Ashley II | \$209,900 | 0.7521033X | 587 | B | Dexter I | \$171,900 | 0.6159436X |
| 569B | A | Emerson | \$242,900 | 0.8703473X | 587 | C | Emerson | \$242,900 | 0.8703473X |
| 570 | A | Ashley II | \$209,900 | 0.7521033X | 588 | A | Essex | \$155,900 | 0.5586132X |
| 570 | B | Emerson | \$242,900 | 0.8703473X | 588 | B | Essex | \$155,900 | 0.5586132X |
| 571 | A | Dexter I | \$171,900 | 0.6159436X | 589 | A | Ashley II | \$209,900 | 0.7521033X |
| 571 | B | Ashley I | \$197,900 | 0.7091055X | 589 | B | Bradford | \$207,900 | 0.7449370X |
| 572 | A | Ashley I | \$197,900 | 0.7091055X | 589 | C | Dexter I | \$171,900 | 0.6159436X |
| 572 | B | Dexter I | \$171,900 | 0.6159436X | 589 | D | Ashley I | \$197,900 | 0.7091055X |
| 572 | C | Bradford | \$207,900 | 0.7449370X | 590 | A | Essex | \$155,900 | 0.5586132X |
| 572 | D | Ashley II | \$209,900 | 0.7521033X | 590 | B | Essex | \$155,900 | 0.5586132X |
| 573 | A | Ashley II | \$209,900 | 0.7521033X | 591 | A | Ashley II | \$209,900 | 0.7521033X |
| 573 | B | Dexter I | \$171,900 | 0.6159436X | 592 | A | Ashley II | \$209,900 | 0.7521033X |
| 573 | C | Ashley I | \$197,900 | 0.7091055X | 592 | B | Ashley II | \$209,900 | 0.7521033X |
| 574 | A | Ashley II | \$209,900 | 0.7521033X | 632 | A | Ashley I | \$197,900 | 0.7091055X |
| 574 | B | Dexter I | \$171,900 | 0.6159436X | 632 | B | Dexter I | \$171,900 | 0.6159436X |

18-A

EXHIBIT
Schedule of Initial Sales Price and
Percentage (%) of Interest on Common Elements

| Bldg. No. | Apt. Des. | Unit Type | Initial Sales Price | % Int. | Bldg. No. | Apt. Des. | Unit Type | Initial Sales Price | % Int. |
|-----------|-----------|-----------|---------------------|------------|-----------|-----------|-----------|---------------------|------------|
| 632 | C | Bradford | \$207,900 | 0.7449370% | 641 | C | Ashley I | \$197,900 | 0.7091055% |
| 632 | D | Ashley II | \$209,900 | 0.7521033% | 642 | A | Emerson | \$242,900 | 0.8703473% |
| 633 | A | Ashley II | \$209,900 | 0.7521033% | 642 | B | Ashley II | \$209,900 | 0.7521033% |
| 633 | B | Dexter II | \$182,900 | 0.6553581% | 643 | A | Emerson | \$242,900 | 0.8703473% |
| 633 | C | Emerson | \$242,900 | 0.8703473% | 644 | A | Emerson | \$242,900 | 0.8703473% |
| 634 | A | Essex | \$155,900 | 0.5586132% | 644 | B | Ashley II | \$209,900 | 0.7521033% |
| 634 | B | Essex | \$155,900 | 0.5586132% | 645 | A | Ashley II | \$209,900 | 0.7521033% |
| 635 | A | Essex | \$155,900 | 0.5586132% | 645 | A | Ashley I | \$197,900 | 0.7091055% |
| 635 | B | Essex | \$155,900 | 0.5586132% | 646 | B | Dexter I | \$171,900 | 0.6159436% |
| 636 | A | Ashley II | \$209,900 | 0.7521033% | 646 | C | Bradford | \$207,900 | 0.7449370% |
| 636 | B | Emerson | \$242,900 | 0.8703473% | 646 | D | Ashley II | \$209,900 | 0.7521033% |
| 637 | A | Ashley II | \$209,900 | 0.7521033% | 647 | A | Ashley II | \$209,900 | 0.7521033% |
| 637 | B | Ashley II | \$209,900 | 0.7521033% | 647 | B | Emerson | \$242,900 | 0.8703473% |
| 638 | A | Ashley II | \$209,900 | 0.7521033% | 648 | A | Emerson | \$242,900 | 0.8703473% |
| 638 | B | Emerson | \$242,900 | 0.8703473% | 649 | A | Ashley I | \$197,900 | 0.7091055% |
| 639 | A | Ashley II | \$209,900 | 0.7521033% | 649 | B | Dexter I | \$171,900 | 0.6159436% |
| 639 | B | Dexter I | \$171,900 | 0.6159436% | 649 | C | Bradford | \$207,900 | 0.7449370% |
| 639 | C | Ashley I | \$197,900 | 0.7091055% | 649 | D | Ashley II | \$209,900 | 0.7521033% |
| 640 | A | Ashley II | \$209,900 | 0.7521033% | 650 | A | Emerson | \$242,900 | 0.8703473% |
| 640 | B | Dexter II | \$182,900 | 0.6553581% | 650 | B | Ashley II | \$209,900 | 0.7521033% |
| 640 | C | Emerson | \$242,900 | 0.8703473% | 651 | A | Ashley II | \$209,900 | 0.7521033% |
| 641 | A | Ashley II | \$209,900 | 0.7521033% | 651 | B | Dexter II | \$182,900 | 0.6553581% |
| 641 | B | Dexter I | \$171,900 | 0.6159436% | 651 | C | Emerson | \$242,900 | 0.8703473% |

BOOK 4080 PAGE 0150

Location Plan

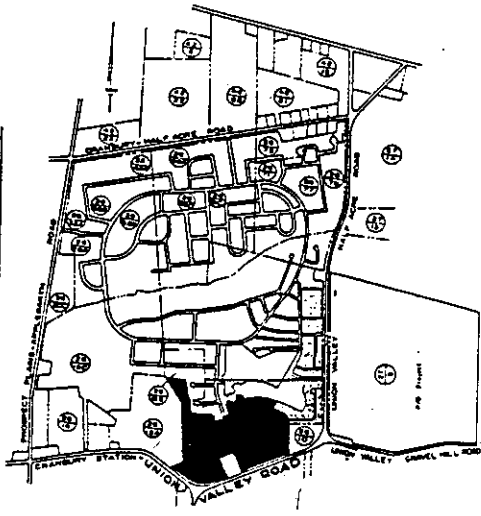

- NOTES:
1. All lots shown on this plan are subject to the provisions of the zoning ordinance of the town of Stuart, Massachusetts.
 2. The lots shown on this plan are subject to the provisions of the zoning ordinance of the town of Stuart, Massachusetts.
 3. The lots shown on this plan are subject to the provisions of the zoning ordinance of the town of Stuart, Massachusetts.
 4. The lots shown on this plan are subject to the provisions of the zoning ordinance of the town of Stuart, Massachusetts.
 5. The lots shown on this plan are subject to the provisions of the zoning ordinance of the town of Stuart, Massachusetts.
 6. The lots shown on this plan are subject to the provisions of the zoning ordinance of the town of Stuart, Massachusetts.
 7. The lots shown on this plan are subject to the provisions of the zoning ordinance of the town of Stuart, Massachusetts.
 8. The lots shown on this plan are subject to the provisions of the zoning ordinance of the town of Stuart, Massachusetts.
 9. The lots shown on this plan are subject to the provisions of the zoning ordinance of the town of Stuart, Massachusetts.
 10. The lots shown on this plan are subject to the provisions of the zoning ordinance of the town of Stuart, Massachusetts.

LEGALLY CERTIFIED THAT THIS PLAN WAS PREPARED BY ME OR UNDER MY SUPERVISION AND THAT I AM A LICENSED PROFESSIONAL ENGINEER IN THE STATE OF MASSACHUSETTS.

[Signature]
 JOHN E. WOOD, P.E. & N.E. 1924

LEGALLY CERTIFIED THAT THIS PLAN WAS PREPARED BY ME OR UNDER MY SUPERVISION AND THAT I AM A LICENSED PROFESSIONAL ENGINEER IN THE STATE OF MASSACHUSETTS.

[Signature]
 JOHN E. WOOD, P.E. & N.E. 1924

OWNER OF PROPERTY:
 GUARDIAN DEVELOPMENT CORP.

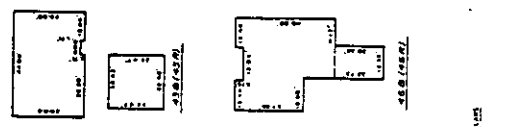

PLANS INDICATE APPROXIMATE
 SCALE: 1" = 10'

TO BE BUILT ON THE APPROVED FLOOR PLAN OF
 THE BUILDING WITH THESE
 SPECIAL REQUIREMENTS: PROVISIONS AND ERECTION
 SHALL BE SUBJECT TO THE
 APPROVAL OF THE BOARD OF HEALTH.

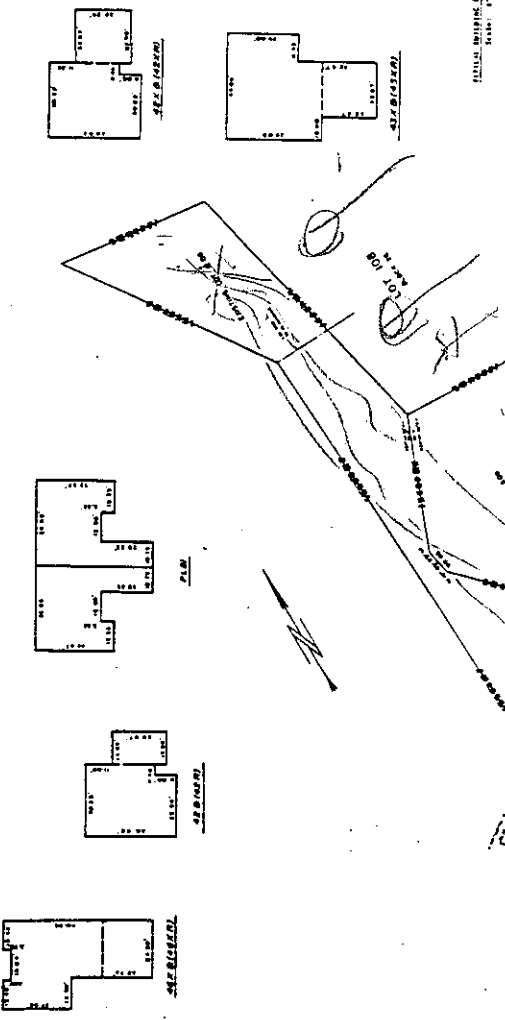

CLEARBROOK
 GUARDIAN DEVELOPMENT CORPORATION
 MONROE TOWNSHIP, MIDDLESEX COUNTY, NEW JERSEY

LYNCH, CARMODY, DILLIARD & KAROL, P.A.
 (INCORPORATED IN MASSACHUSETTS)
 PROFESSIONAL ENGINEERS
 BRIAN S. FLANNERY
 PROFESSIONAL ENGINEER
 100 STATE STREET, SUITE 200
 BOSTON, MASSACHUSETTS 02109
 PHONE: 617-552-1234
 FAX: 617-552-1235
 E-MAIL: bflannery@lynchcarmody.com

STUART VILLAGE
 SURVEY & EASEMENT PLAN
 APPROVED BY THE BOARD OF HEALTH OF THE TOWN OF STUART, MASSACHUSETTS, ON 10/15/05.
 FILE NO. 2005-10-15
 SHEET 1 OF 1

DEFINITIVE NOTICE OF RECORDING, DRAWINGS
 This drawing is a preliminary drawing and is not to be used for construction purposes. It is subject to change without notice. The owner of the property is responsible for obtaining all necessary permits and approvals from the appropriate authorities. The engineer's responsibility is limited to the design and construction of the project as shown on these drawings.